

Turbo-Meters Mark-II and Auto-Adjust®

Installation and Maintenance Instructions

THE GAS INDUSTRY

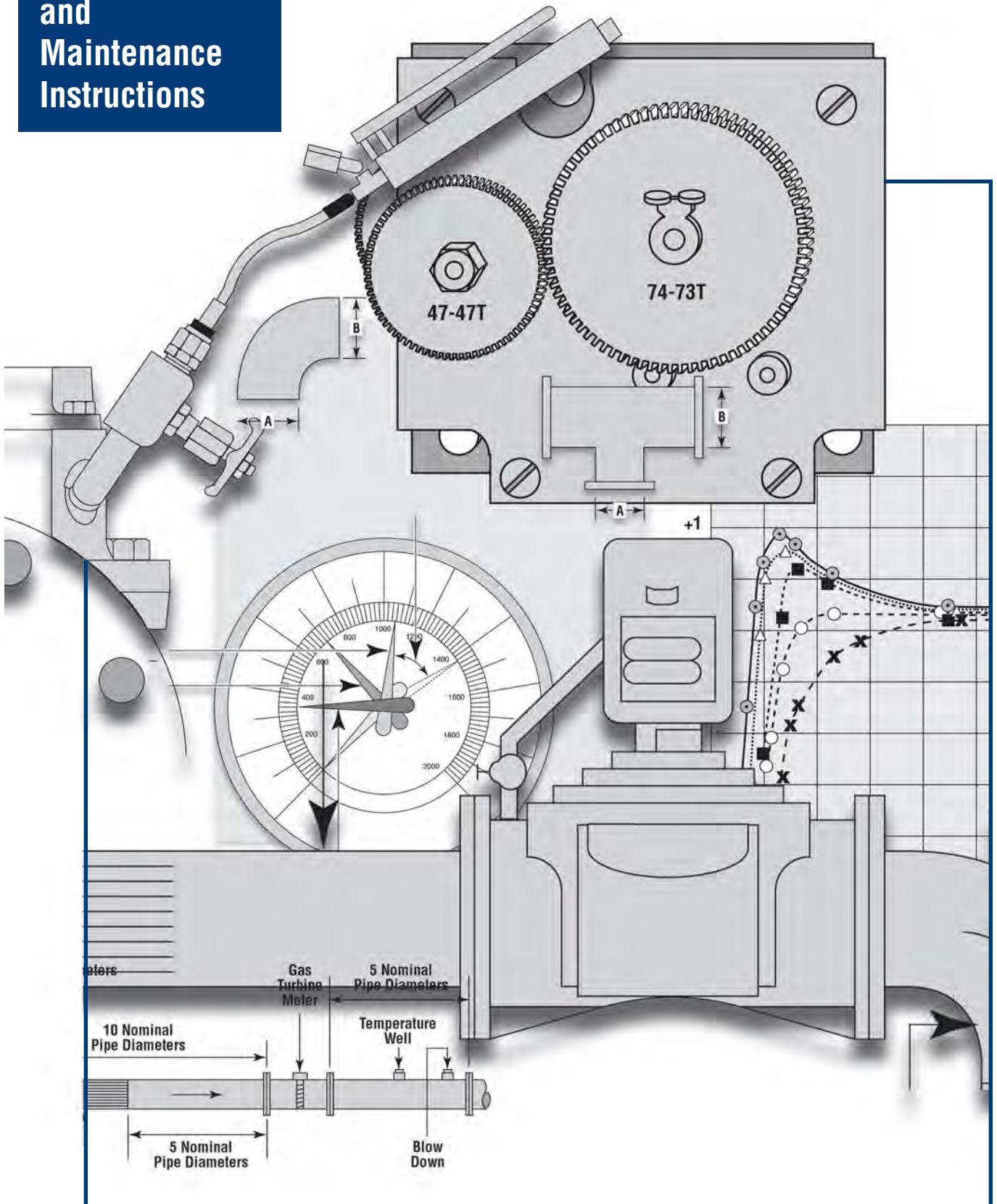

Installation and Maintenance Instructions

Mark-II and Auto-Adjust®

Sensus Metering Systems Turbo-Meters are designed for the measurement of gas. Proper application and routine maintenance will result in many years of active service life.

The following instructions are in general conformance with the recommendations contained in American Gas Association, Gas Measurement Committee Report #7, "Measurement of Gas by Turbine Meters."

On Receipt

Carefully examine the shipping container for any external damage prior to unpacking. Any evident damage should be reported to the carrier.

After unpacking the meter, examine it for compliance with your ordering specifications. Report any deviations to your Sensus representative.

RETAIN ALL DOCUMENTS SHIPPED WITH THE METER SINCE THESE ARE REQUIRED FOR METER RECORDS.

Product Specifications

Mark-II and Auto-Adjust Turbo-Meters all use the same meter bodies, with flange dimensions conforming to ANSI B16.42 and B16.5 standards.

All Turbo-Meter bodies are hydrostatically tested at a minimum of 1.5 times the maximum rated working pressure indicated on the meter body badge. The maximum rated working pressure stamped on the meter body badge must not be exceeded in service.

Standard construction aluminum, ductile iron and steel bodied Turbo-Meters will operate over a flowing gas temperature range of -20°F to + 165°F (-28.9°C to + 74°C). Special construction is available for lower and higher operating temperatures.

Installation

Turbo-Meters are basically velocity sensing devices which derive volume by sensing the flow rate through the known cross-sectional area of the measuring module. Accurate velocity sensing is essential in deriving accurate volume measurement.

Accessory devices in close proximity to the Turbo-Meter set can cause a jetting or swing condition, upsetting the normal velocity profile of the gas stream. Extensive tests of Turbo-Meters at various flow rates and pressures have defined the recommended piping installations which should result in optimal volume measurement accuracy.

The most common installations are as follows:

- 1. Inline** A minimum run of ten (10) pipe diameters (DN) of straight pipe must be used between any flow-altering device (other than flow throttling) and the inlet flange of the Turbo-Meter (Figure 1).

Note: A total of eighteen (18) pipe diameters must be used between any throttling device (regulator, control valve, etc.) installed upstream of the meter and the meter inlet flange. This inlet pipe should be nominally the same interior diameter as the meter body. Minor variations in the piping ID due to use of piping with different wall thickness will not affect the meter accuracy. Inline straightening vanes locate five pipe diameters upstream of the meter inlet are optional. Extensive testing in lines with and without straightening vanes mounted in the inlet piping demonstrates no difference in accuracies when using Turbo-Meters with built in straightening vanes.

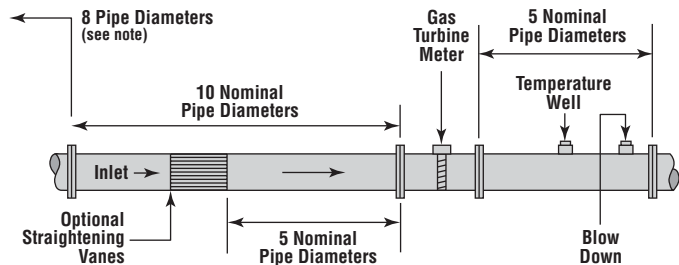

Figure 1

Recommended Installation of an In-Line Gas Turbine Meter (Minimum Lengths)

Note: A throttling device (regulator control valve, etc.) upstream of the meter run requires a minimum of eight (8) pipe diameters (DN) between such device and the meter run.

- 2. Off-Set, Short Coupled** Turbo-Meters may be installed in short-coupled sets as illustrated in Figure 2. Note that the flow-restricting devices must be installed in the vertical riser and that a 90° fitting must be used at the inlet to the meter run. This fitting may be an elbow or a tee. A straight run of pipe, equal in ID to the meter size and four diameters long, as well as equipped with straightening vanes at the inlet end, is attached to the inlet side of the meter.

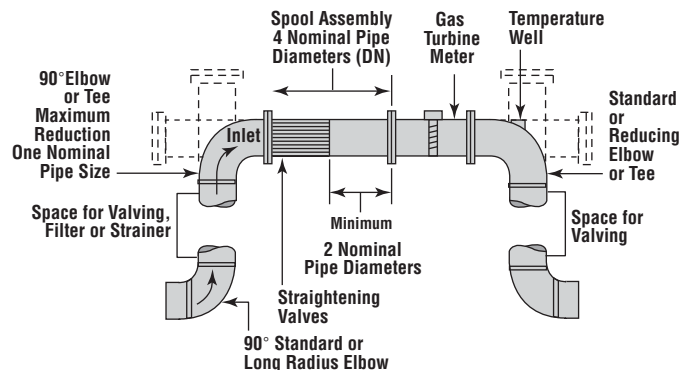

Figure 2

Short Coupled Installation of an In-Line Gas Turbine Meter (Minimum Lengths)

Installation and Maintenance Instructions

Mark-II and Auto-Adjust®

3. **Offset, Close Coupled** Sensus Turbo-Meters manufactured since October, 1974 incorporate integral straightening vanes. This design eliminates the need for long inlet runs and enables Turbo-Meters to be close-coupled as illustrated in Figure 3.

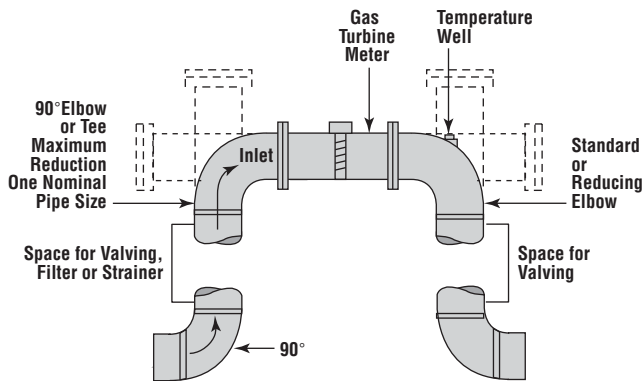

Figure 3

Closed Coupled Installations of an In-Line Gas Turbine Meter with Integral Straightening Vanes

The two 90° turns into the inlet end of the short or close coupled meter runs must be in the same plane to ensure an even velocity profile at the meter inlet. The 90° turn can be accomplished with either elbows or tees. Reducing fittings can be used. However, the maximum reductions at the inlet end are as shown in figure 4. The fittings used on the piping down-stream of the meter are not critical except that the connection to the meter outlet flange must be equal in ID to the meter ID.

In-line dimensions for Turbo-Meters are as follows:

Meter Size	Max Pressure Rating (PSIG)*	In-Line Dimensions
4"	175	14
4"	HP	15 1/2
6"	175	16
6"	HP	22 1/2
8"	175	21
8"	HP	27 1/4
12"	220	30
12"	HP	32 1/2

Figure 4

Maximum Reductions

A	B
4"	3"
6"	4"
8"	6"
12"	8"

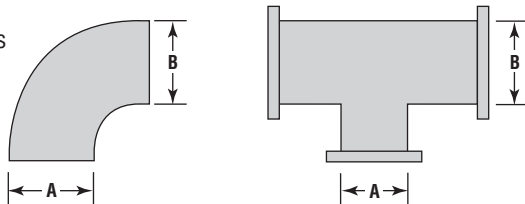

Installation Notes:

- A. Piping fabrication, welding, purging and hydrostatic testing must be completed prior to installation of the Turbo-Meter in line.
- B. An installation of a by-pass line around the meter is recommended for all piping configurations (refer to figure 5.)
- C. Companion pipe flanges at the meter inlet and outlet should be concentrically aligned with no gasket protrusion into the flow pattern.
- D. Pipe interior should be of commercial roughness with no protruding welds.

Vertical Installation

Turbo-Meters may be installed in the vertical position with the meter inlet up or down. To achieve adequate rotor shaft bearing lubrication, the pressurized lubrication procedure must be used. Inlet piping specifications on vertical installations are identical to those detailed for horizontal installations. Although vertical installations are acceptable, Turbo-Meters in the horizontal position are the preferred method of installation.

Prover Connections

Where low pressure or critical flow provers or transfer provers will be used to field prove Turbo-Meters, it is important to locate the prover connections so that the normal flow pattern through the meter is duplicated. Tees, located at the meter inlet and outlet equipped with blind flanges and 2" and 3" pipe plugs can be used for this purpose.

Pressure connections for instrumentation are located on the inlet ends of the meter body or the top plate. Please note that some meters may have both a body and top plate tap. Use the top plate tap in these instances. Temperature connections for either corrective or recording instruments should be located downstream within two pipe diameters of the meter flange

The recommended maximum rate of pressure change is 100 psig per minute when decreasing pressure and 67 psig per minute when increasing pressure.

Blow-Down

Provision for a controlled pressure blow-down of the meter run should be made. The blow-down should be located between the meter outlet flange and the downstream block valve (shown in figure 5). While Turbo-Meters can be operated up to 150 percent of maximum rated capacity for short periods of time with no damaging effects, over-sized blow-downs can cause speeds greatly in excess of this amount. On inside meter sets, blow-down should not be sized larger than one-sixth the meter size as described in the following table:

Meter Size	Blow-Down Size
2"	1/4"
3"	1/2"
4"	1/2"
6"	1"
8"	1"
12"	1"

Body Drain

Every Turbo-Meter body is supplied with a body drain plug that can be used to remove any accumulated liquids. This drain can be fitted with a 1/4" valve, allowing liquids to be expelled periodically without interrupting the meter operation.

Filters/Strainers

Where excessively dirt gas conditions are present, a filter or strainer should be installed upstream of the Turbo-Meter in the location shown in the installation drawings.

The maximum recommended particle size flowing through the meter should be no greater than 140 microns (typically 100 mesh strainer).

Start-Up (Refer to Figure 5)

1. Valve C open, valves A, B and D closed
2. Slowly* open valve A
3. When meter stops registering, slowly open valve B
4. Close valve C.

*Slowly is defined as a flow rate change from 0 ACFH to 100% in not less than 30 seconds. This is also a linear relationship for valve control.

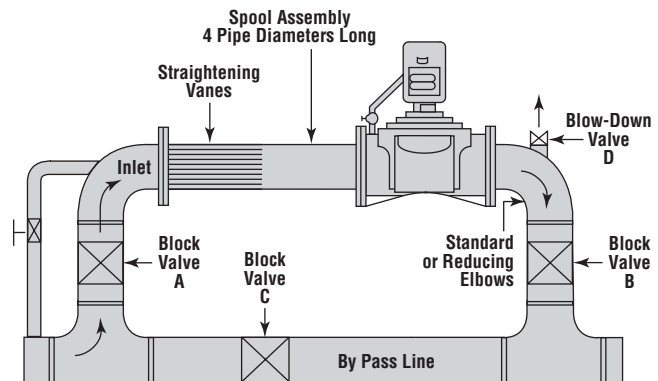

Figure 5

On high pressure installations, a valved bypass around the inlet riser block valve ("A" in Figure 5) is recommended. Usually constructed of 3/4" pipe, with a needle-type valve, the by-pass permits pressurizing of the meter run without damaging the meter. Once the inlet pressure has been achieved, as indicated by lack of any registration on the meter, the needle valve is closed and Steps #2, #3 and #4 in start-up procedure should be followed.

Shut Down (Refer to Figure 5)

1. Open Valve C
2. Slowly close valve B
3. Slowly close valve A
4. Carefully open valve D

Note on Bypass Lines

If a bleed-to-line pilot loaded pressure regulator is installed upstream of the meter, the control line must also be attached upstream of the meter. Installation of the control line downstream of the meter constitutes a bypass which can result in significant volumes of unmeasured gas at elevated pressure.

Lubrication

CAUTION

The lubrication system is subject internally to full line pressure. Follow the procedures as detailed to prevent blowing gas to the atmosphere. ALWAYS leave the lubricating system valve closed except when actually lubricating the meter. NEVER use the lubrication system to blowdown pressure in the meter. Doing so will force any line contaminants directly into the bearings. NEVER attach static pressure lines from either recording or integrating gauges to the lubrication system.

The rotor shaft bearings MUST be lubricated prior to putting the meter into service, using the approved Turbo-Meter oil shipped with the meter.

The most effective lubrication procedure for a Turbo-Meter is the pressure method which provides positive lubrication and flushing of the rotor shaft bearings by use of a manual handgun.

The pressure method should always be utilized for the Auto-Adjust Turbo-Meters to ensure proper lubrication to both the main and sensing rotor bearings. The pressure method is also the recommended method for the Mark-II Turbo-Meter. However, an optional gravity feed or automated lubrication equipment can be used with the Mark-II Turbo-Meters.

It is also recommended to periodically add a drop or two of oil to the top of the follower magnet assembly, located in the unpressurized gear box under the intermediate gear train assembly.

Lubrication Procedure

A. Pressure Lubrication:

1. Remove protective cap from the lubrication fitting (See Figure 6). Open lubrication valve and check for leakage through the ball-check in the Alemite fitting. If the fitting leaks, close the valve and replace the fitting prior to lubricating the meter.
2. Set the lubrication handgun handle to either the "Volume" or "Pressure" setting by sliding the button on the pump handle. The "Pressure" setting will deliver approximately 1/3 the amount of oil as the "Volume" setting, but more easily overcomes meter pressure while pumping the handle.
3. Securely attach the coupler of the handgun to the Alemite fitting on the meter. Hold the pump end of the lubricating gun down to allow oil to fill the pump chamber.
4. Begin pumping the gun lever, observing the pressure gauge while doing so. The gauge will indicate a higher pressure with each stroke until the internal pressure is overcome. When this occurs, the pressure gauge needle will bounce between two points (See Figure 7).
5. When set to the volume pump setting, six pumps of the gun after the internal pressure has been overcome will provide about 6 cc of oil, which should be sufficient for lubricating the meter. When set to the pressure pump setting, 18 pumps after overcoming initial pressure will provide the 6 cc of oil. On either setting, additional pumps may be made to flush out the bearings. The lubrication system is an open system, and as such, the meter cannot waste Turbo-Meter oil and induce excess oil downstream.

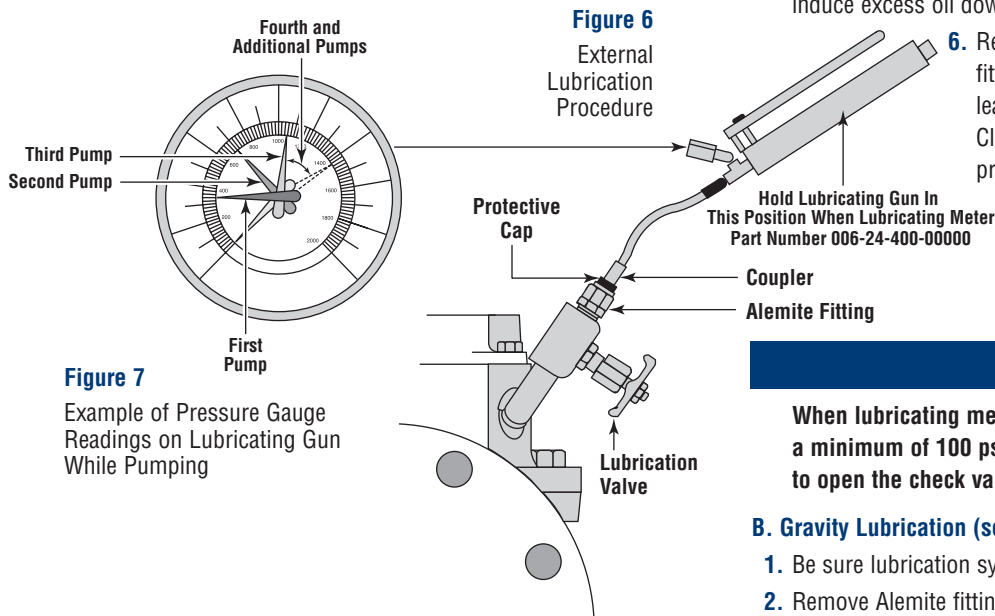

Figure 7

Example of Pressure Gauge Readings on Lubricating Gun While Pumping

Note:

The Turbo-Meter will not be lubricated unless the check valve in the meter lube fitting is opened. One or two pumps of the gun, after the gun is primed, will open the check valve

6. Remove the gun coupler from the lube fitting of the meter. Again, check for any leakage through the Alemite fitting. Close the lubrication valve and replace the protective cap on the Alemite fitting.

CAUTION

When lubricating meters operating at low line pressures, a minimum of 100 psig must be obtained on the gauge to open the check valves in the meter lube system.

B. Gravity Lubrication (see figure 6)

1. Be sure lubrication system valve is securely closed.
2. Remove Alemite fitting
3. Fill inlet of valve with recommended Turbo-Meter oil
4. Using thread sealant, re-install Alemite fitting securely.
5. Cycle lubrication system valve full open to full closed.
6. Repeat steps "1" through "5" above for a total of three times.
7. Leave lubrication system valve closed.

Installation and Maintenance Instructions

Mark-II and Auto-Adjust®

Recommended Lubrication Oils

Sensus Turbo-Meter oil specifications conform to Military Specifications MIL-L-6085A. Generally, this specification refers to a synthetic, diester-based lubricating oil with an SAE viscosity number of 5W containing NO PCBs. Recommended Turbo-Meter lubrication oils and the sources of supply are as follows:

Oil Source	Source
Chemlube #201	Ultra-Chem Corporation 900 Centerpoint Blvd. New Castle, Delaware 19720 Telephone: 302-325-9880
Anderol 401D	Call Anderol 973-887-7410 Ext. 115 For Local Anderol Distributor

Recommended lubrication oil is available from Sensus in small plastic bottles and one gallon cans as follows:

4 oz. bottle – Sensus Part Number 006-22-405-01000

One gallon can – Sensus Part Number 006-22-405-02000

Handguns

Two lubricating handguns are available including a pressure gauge and, importantly, a relief valve, as follows:

High pressure application (0-2000 psig)
Sensus Part Number 006-24-400-00000

Low pressure application (0-600 psig)
Sensus Part Number 006-24-400-01000

Frequency of Lubrication

The frequency of lubrication required in order to maintain the rotor shaft bearings in good operating condition is a function of the severity of the service. High pressure, high flow rates, and high temperatures, coupled with dirty gas conditions require more frequent lubrication. Lubricate the bearings following the detailed procedure at the time the initial installation is made with the oil shipped with the meter. Subsequent lubrication should be done monthly with the period extended as operating conditions permit. Lubrication of the meter prior to installation will result in the inconvenience of oil flowing out of the open system.

Mechanical Readout and Instrumentation Mounting

Mechanical indexes and electronic volume correctors all mount directly on the Turbo-Meter index plate. (See Figure 8). With all in-line Sensus Turbo-Meters, one counter-clock-wise 360° revolution of the meter output shaft is representative of a precisely known volume of gas at line conditions. For 4" and 6" Turbo-Meters of standard construction, one revolution of the output shaft can equal 100 cubic feet or 1.0 cubic meter of gas at line conditions. For 8" and 12" Turbo-Meters, one revolution of the output shaft can equal 1000 cubic feet or 10 cubic meters of gas at line conditions.

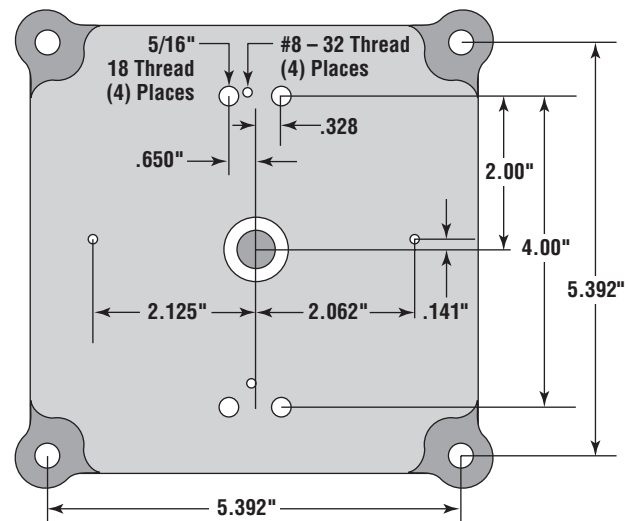

Figure 8
Turbo-Meter Index Plate

Meter accessories are available to provide read-outs in desired units at line conditions or corrected for pressure, temperature or both. These accessories fit directly on the index plate without special adapters and are provided with weather-proof cases. Read-out units can be in either cubic feet or cubic meters. All meter-mounted instruments can provide pulse outputs for remote reading.

Special intermediate gear train assemblies are available to provide different volume values per revolution of the meter output shaft. Be sure the readout device used is matched to the direction of rotation and the value per revolution of the meter output shaft. Failure to do so will result in significant measurement error or damage to the readout device.

AGA Report #7 states that accessory devices and instrumentation must be properly installed and maintained to prevent excess torque loads on the Turbo-Meter. High Torque loads may degrade the meter accuracy at low flows and accelerate gear train wear. Generally, retarding torques should be less than 2 in. – oz.

Installation and Maintenance Instructions

Mark-II and Auto-Adjust®

Periodic Inspection

CAUTION

All pressure in the meter run must be relieved to a non-hazardous location prior to the disassembly of the meter

The meter mechanism should be inspected periodically to ensure that all components are in good operating condition. The frequency of inspection is a function of the severity of the application. A meter operating at or near its maximum rated capacity at high pressure on a “dirty” gas application will require more frequent inspection than a meter on a less severe application. The recommended periodic inspection procedure is as follows:

1. Follow previously defined steps for “SHUT-DOWN”
2. Remove the readout device from the meter. The high frequency device must also be removed on end-entry type meters.
3. After all pressure inside the meter has been relieved, remove bolts attaching meter top plate to the body (see Parts List Illustration). For end entry type meters, remove the screws retaining the nosecone. Meters with center set screws may be replaced with an eye bolt or similar item for extraction.
4. Carefully lift the complete internal mechanism assembly vertically out of the meter body. Note: Two opposing bolt holes in the top plate are tapped to accept eye bolts to aid in lifting the module out. For end entry type meters, remove the measuring module through the inlet side.
5. Hang the internal mechanism assembly from the meter body so that two bolt holes in the top plate line up with two holes in the body. Insert two bolts to firmly attach mechanism to body.
6. Visually inspect the interior of the body. Remove any liquid or debris which may be present. Use an angled inspection mirror and flashlight to look for bent, missing or otherwise damaged straightening vanes attached to the nosecone. A damaged nosecone may be replaced without recalibration of the module.
7. Visually inspect the rotor and flow passages of the internal housing assembly. A damaged rotor should be replaced, and the meter recalibrated.
8. While shielding the mechanism from extraneous air currents, conduct a “Spin Test” of the mechanism using the following procedure. See figure 9 for an example of the effect of spin time on proof.
 1. With a finger (Mark-II only) or air jet (T-10 or Auto-Adjust only), forcibly spin the rotor in operating direction.
 2. Determine the time in seconds for the free-spinning rotor to come to a halt. Record this time.
 3. Repeat this procedure three times and determine the average time in seconds obtained.
 4. Compare the average spin time (derived from tests) to the preceding tables.

Minimum Spin Times in Seconds

Mark-II Turbo-Meters

Complete meter less readout

2" – 3" T-10 All Pressure	*4" T-18 All Pressure	4" T-18/27 All Pressure	6" T30 All Pressure	6" T35/57 All Pressure	*8" T-60 ANSI 125	8" T-60/90 All Pressures	12" T-140/230 All Pressures
50	50	70	90	140	170	180	300

*Plastic Rotor

Mark-II Turbo-Meters

Internal Housing Assembly only

2" – 3" T-10 All Pressure	*4" T-18 All Pressure	4" T-18/27 All Pressure	6" T30 All Pressure	6" T35/57 All Pressure	*8" T-60 ANSI 125	8" T-60/90 All Pressures	12" T-140/230 All Pressures
70	70	90	125	150	185	195	325

*Plastic Rotor

Auto-Adjust Turbo-Meters

Complete meter less readout

Meter	Main Rotor	Sensing Rotor
4" AAT-18/27	110	200
6" AAT-35/57	170	200
8" AAT-60/90	300	300
12" AAT-140/230	400	300

PT Turbo-Meters

Complete meter less readout

Meter	Minimum Spin Time (Seconds) for 20:1 Range	Minimum Spin Time (Seconds) for 15:1 Range
4" PT-18	13	8
6" PT-30	35	20
8" PT-60	25	14

The following table shows the expected degradation in spin time at cold temperatures

Meter Temperature °F	Degradation in Minimum Spintime
60	0
50	2%
40	5%
30	10%
20	15%

Note:

Spin Testing below 20°F is not recommended since degradation due to increased oil viscosity cannot be distinguished from wear or damage.

Installation and Maintenance Instructions

Mark-II and Auto-Adjust®

NOTE

When spin-testing an Auto-Adjust Turbo-Meter, Sensus recommends that an air jet be used on the inlet side to spin both rotors simultaneously. The air jet should remain on until the sensing rotor is spinning in the same direction as the main rotor.

9. Failure to achieve the specified spin time most probably indicates a need to lubricate the rotor shaft bearings following the previously defined procedure. After lubricating the bearings, forcibly spin the rotor several minutes to throw off excess oil prior to repeating the spin test.
Spin times above the minimums listed are typical, and indicate a meter with acceptable friction levels and accuracy.
10. Inspect top plate to body "o" ring and replace if necessary. Inspect the module/oil seal and replace if necessary.
11. Remove bolts attaching top plate to body (see 5). End entry meters equipped with an aligning pin should be positioned with the inside groove of the inlet.
12. Carefully insert measuring module into body being sure rotor is positioned toward the inlet end. DO NOT FORCE.

13. Re-insert top plate body bolts and tighten securely. Replace the nosecone retaining screw on end entry meters and re-apply loctite on set screw equipped modules.
14. Mount readout device on index plate being careful to properly align the driving mechanism from the meter to the driving mechanism on the index or instrument.
15. Re-pressure the meter following the Start-Up procedure previously identified (page 3).
16. Check top plate to body joint for leaks.
17. Following start-up, check the readout device for proper registration.
18. Before leaving the meter site, it is best to lubricate the meter once it is pressurized and gas is flowing through it.

Figure 9

T-35 Mark-II Turbo-Meter Effect of Spin Time on Proof

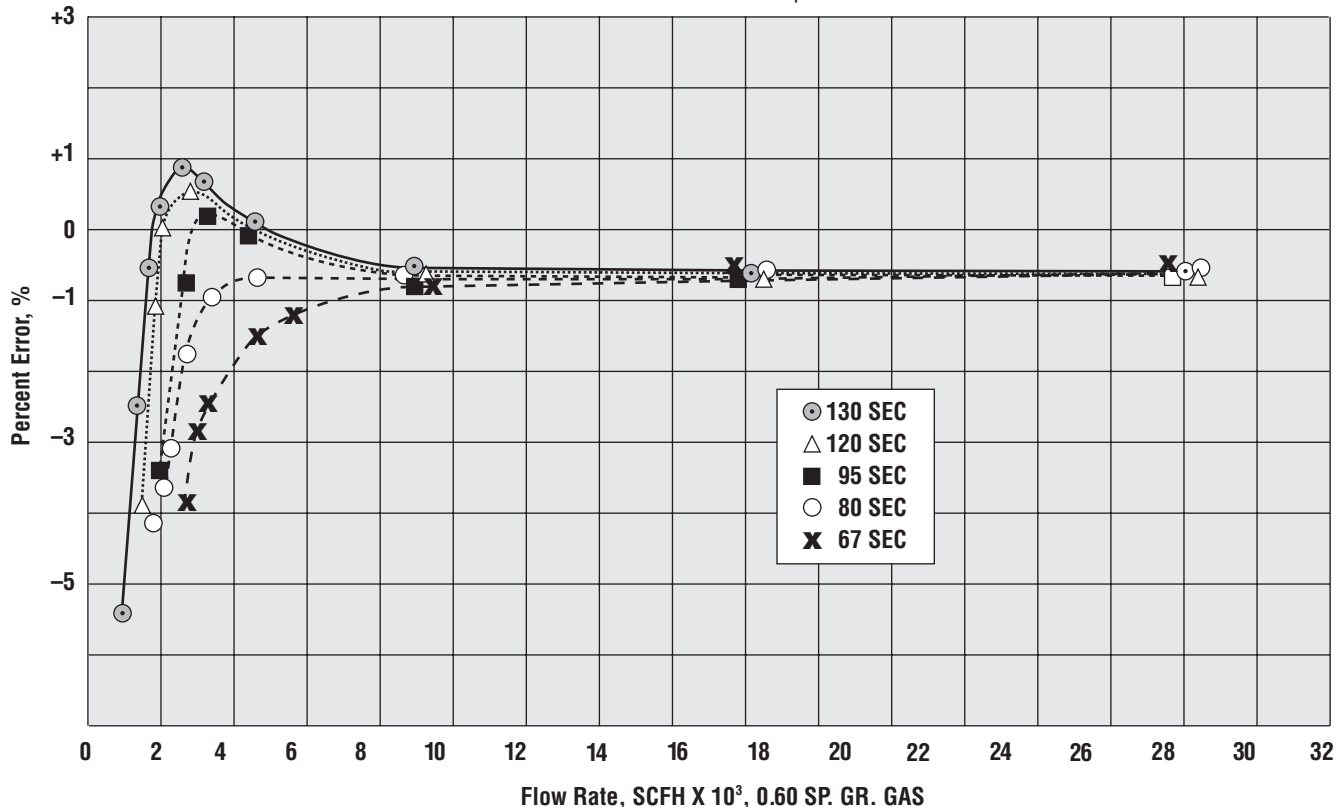

Installation and Maintenance Instructions

Mark-II and Auto-Adjust®

Proof Setting of Turbo-Meters

Each Turbo-Meter is individually calibrated to assure optimum meter accuracy to Sensus and customers' specifications. Sensus calibration is conducted with some of the most automated, computerized and sophisticated equipment in the world.

Paired change gears are used to set the mechanical output accuracy. These are precision machined gears which, in combination, provide exact mathematical ratios. Various gear combinations are used so that meter output shaft revolutions are in accurate engineering units.

The electronic output accuracy of Auto-Adjust Turbo-Meters or single rotor Mark II Turbo-Meters with pulsers is set using K-factors or Pulse factors. These are also referred to as coefficients. They are burned onto PROM chips or programmed into flow computers or electronic instruments.

A calibrated curve including specific detail on the change gears installed and specific pulse factors are provided with each Turbo-Meter shipped. For in-line Turbo-Meters, the change gears are mounted on top of the intermediate gear train assembly (Figure 10).

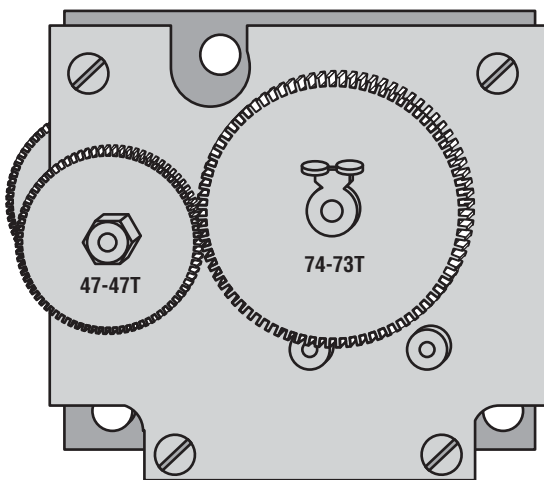

Figure 10

The multiplying action of the change gears does not alter the basic configuration or shape of the typical meter proof curve. Instead, the entire curve is moved vertically in precisely known increments.

Because all Turbo-Meters are calibrated under controlled laboratory conditions, field replacement or substitution of alternate combinations of change gears is usually not necessary. Making unnecessary substitutions of change gears amounts to treating the symptoms, rather than the cause of a proof shift in Turbo-Meter. The exception to this statement is substitution of a new rotor blade.

Replacement measuring modules are shipped with their own change gears. When changing modules in the field, it is important to keep the change gear sets with their specific modules.

Item	Change Gear and Basic Blanks	Ratio	% of change in Meter Registration
1	66-63 T/55-58T	1.08620	1.574
2	66-64 T/55-58T	1.10344	0.164
3	66-63 T/55-57T	1.10526	1.385
4	66-65 T/55-58T	1.12068	0.188
5	66-64 T/55-57T	1.12280	0.195
6	66-63 T55-56T	1.12500	1.142
7	66-66 T/55-58T	1.13793	0.212
8	66-65 T/55-57T	1.14035	0.218
9	66-64 T/55-56T	1.14285	0.227
10	66-63 T/55-55T	1.14545	0.844
11	66-67 T/55-58T	1.15517	0.235
12	66-66 T/55-57T	1.15789	0.243
13	66-65 T/55-56T	1.16071	0.251
14	66-64 T/55-55T	1.16363	0.260
15	66-63 T/55-54T	1.16666	0.491
16	66-68 T/55-58T	1.17241	0.257
17	66-67 T/55-57T	1.17543	0.266
18	66-66 T/55-56T	1.17857	0.274
19	66-65 T/55-55T	1.18481	0.284
20	66-64 T/55-54T	1.18518	0.294
21	66-63 T/55-53T	1.18867	0.082
22	66-69 T/55-58T	1.18965	0.279
23	66-68 T/55-57T	1.19298	0.289
24	66-67 T/55-56T	1.19643	0.299
25	66-66 T/55-55T	1.20000	0.309
26	66-65 T/55-54T	1.20370	0.319
27	66-64 T/55-53T	1.20755	0.247
28	66-69 T/55-57T	1.21053	0.084
29	66-63 T/55-52T	1.21154	0.227
30	66-68 T/55-56T	1.21429	0.321
31	66-67 T/55-55T	1.21818	0.332
32	66-66 T/55-54T	1.22222	0.112
33	66-65 T/55-53T	1.22642	0.355
34	66-64 T/55-52T	1.23077	0.112
35	66-69 T/55-56T	1.23214	

To Increase % Registration

To Decrease % Registration

Installation and Maintenance Instructions

Mark-II and Auto-Adjust®

Item	Change Gear and Basic Blanks	Ratio	% of change in Meter Registration
35	66-69 T/55-56T	1.23214	0.343
36	66-68 T/55-55T	1.23636	0.354
37	66-67 T/55-54T	1.24074	0.366
38	66-66 T/55-53T	1.24528	0.379
39	66-65 T/55-52T	1.25000	0.364
40	66-69 T/55-55T	1.25455	0.376
41	66-68 T/55-54T	1.25926	0.388
42	66-67 T/55-53T	1.26415	0.402
43	66-66 T/55-52T	1.26923	0.673
44	66-69 T/55-54T	1.27778	0.410
45	66-68 T/55-53T	1.28302	0.424
46	66-67 T/55-52T	1.28846	0.608
47	69-70 T/52-54T	1.29630	0.431
48	66-69 T/55-53	1.30189	0.446
49	71-68 T/50-52T	1.30769	0.000
50	66-68 T/55-52T	1.30769	0.461
51	69-67 T/52-51T	1.31373	0.535
52	69-70 T/52-53T	1.32075	0.467
53	66-69 T/55-52T	1.32692	0.000
54	71-69 T/50-52T	1.32692	0.483
55	71-68 T/50-51T	1.33333	0.500
56	69-67 T/52-50T	1.34000	0.459
57	71-70 T/50-52T	1.34615	0.504
58	71-69 T/50-51T	1.35294	0.522
59	71-68 T/50-50T	1.36000	0.396
60	71-71 T/50-52T	1.36538	0.525
61	71-70 T/50-51T	1.37255	0.543
62	71-69 T/50-50T	1.38000	0.334
63	71-72 T/50-52T	1.38462	0.227
64	71-68 T/50-49T	1.38776	0.317
65	71-71 T/50-51T	1.39216	0.563
66	71-70 T/50-50T	1.40000	0.275
67	71-73 T/50-52T	1.40385	0.308
68	71-69 T/50-49T	1.40816	0.256
69	71-72 T/50-51T	1.41176	0.347
70	71-68 T/50-48T	1.41667	0.235
71	71-71 T/50-50T	1.42000	0.217
72	71-74 T/50-52T	1.42308	0.386
73	71-70 T/50-49T	1.42857	0.196
74	71-73 T/50-51T	1.43137	

To Increase % Registration

To Decrease % Registration

Item	Change Gear and Basic Blanks	Ratio	% of change in Meter Registration
74	71-73 T/50-51T	1.43137	0.428
75	71-69 T/50-48T	1.43750	0.174
76	71-72 T/50-50T	1.44000	0.624
77	71-71 T/50-49T	1.44898	0.138
78	71-74 T/50-51T	1.45098	0.507
79	71-70 T/50-48T	1.45833	0.114
80	71-73 T/50-50T	1.46000	0.643
81	71-72 T/50-49T	1.46939	0.666
82	71-71 T/50-48T	1.47917	0.056
83	71-74 T/50-50T	1.48000	0.662
84	71-73 T/50-49T	1.48980	0.685
85	71-72 T/50-48T	1.50000	0.680
86	71-74 T/50-49T	1.51020	0.000
87	74-74 T/47-49T	1.51020	0.704
88	71-73 T/50-48T	1.52083	0.000
89	74-73 T/47-48T	1.52083	0.643
90	74-75 T/47-49T	1.53061	0.085
91	74-72 T/47-47T	1.53191	0.637
92	71-74 T/50-48T	1.54167	0.000
93	74-74 T/47-48T	1.54167	0.118
94	74-71 T/47-46T	1.54348	0.489
95	74-76 T/47-49T	1.55102	0.140
96	74-73 T/47-47T	1.55319	0.599
97	74-75 T/47-48T	1.56250	0.571
98	74-77 T/47-49T	1.57143	0.193
99	74-74 T/47-47T	1.57447	0.563
100	74-76 T/47-48T	1.58333	0.229
101	74-73 T/47-46T	1.58696	0.554
102	74-75 T/47-47T	1.59574	0.528
103	74-77 T/47-48T	1.60417	0.282
104	74-74 T/47-46T	1.60870	0.518
105	74-76 T/47-47T	1.61702	0.322
106	74-73 T/47-45T	1.62222	0.506
107	74-75 T/47-46T	1.63043	0.482
108	74-77 T/47-47T	1.63830	0.375
109	74-74 T/47-45T	1.64444	0.470
110	74-76 T/47-46T	1.65217	0.419
111	74-73 T/47-44T	1.65909	0.457
112	74-75 T/47-45T	1.66667	0.435
113	74-77 T/47-46T	1.67391	

To Increase % Registration

To Decrease % Registration

Installation and Maintenance Instructions

Mark-II and Auto-Adjust®

Change Gear Tables

The following tables list base change gears used for initial installation.

Mark-II Turbo Meters		Auto-Adjust Turbo-Meters (All Pressure Ratings)		Auto-Adjust II Turbo-Meters (All Pressure Ratings)	
Model	Base	Model	Base	Model	Base
4" T-18 All Pressures	74-73T/47-47T	4" AAT-18	71-70T/50-48T	4" AAT-18 II	71-72T/50-51T
4" T-27 All Pressures	71-70T/50-49T	6" AAT-30	71-74T/50-52T	4" AAT-27 II	71-68T/50-48T
6" T-30, ANSI 125 (175# W.P.)	74-71T/47-46T	8" AAT-60	71-72T/50-48T	6" AAT-35 II	71-72T/50-51T
6" T-35, All Pressures	71-73T/50-51T	12" AAT-140	66-68T/55-55T	6" AAT-57 II	66-66T/55-57T
6" T-57 All Pressures	71-68T/50-48T			8" AAT-60 II	71-72T/50-51T
8" T-60, ANSI 125 (175# W.P.)	74-77T/47-48T			8" AAT-90 II	71-71T/50-50T
8" T-60, ANSI 150,300,600 (275#,720#,1440#, W.P.)	74-74T/47-46T			12" AAT-140 II	66-68T/55-55T
8" T-90 All Pressures	71-70T/50-50T			12" AAT-230 II	50-49T/71-70T
12" T-140 All Pressures	69-67T/52-51T				
12" T-230 All Pressures	50-49T/71-70T				

Ordering Change Gears

1. Change gear orders must specify blank size and number of teeth for each gear.
2. The number of teeth is indicated by "T". The first number is the gear blank size that a particular gear is cut upon.
3. A gear cut on one size blank cannot be substituted for a gear cut on a different size blank - even when they have the same number of teeth. Example: Item 47, 52-54T gear cannot be used in place of item 44, 55-54T.
4. The gears can be used in any of the combinations shown. The total of gear blank sets must equal 121 to fit gear centers.

Change gears are individually stamped with two sets of numerical data. A large change gear for a 4" T-18 might be stamped "74-737T." The "74" relates to the gear blank size. The "737T" defines the number of teeth on one gear. Orders for change gears must specify both the blank size and number of teeth on one gear.

Example:

Proving of an 8" T-60 175# WP Turbo-Meter against an accurate reference standard reveals the Turbo-Meter is 1.00% slow. Inspection of the change gears reveals the gears are stamped "74-77T/47-48T." Reference to the change gear table reveals that switching to a "74-75T/47-47T" gear set will speed up the meter by 0.528% Similarly switching to a "74-737T/47-46T" gear set will speed up the meter by (0.528 plus 0.554) = 1.082%.

EXAMPLE

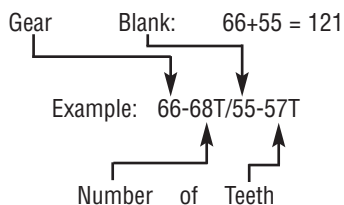

ORDERING NOTE

Description	Part Number
Large Change Gear	006-24-3xx-yy
Small Change Gear	066-24-3xx-yy

Note:

"xx" Refers to gear blank size.
 "yy" Refers to number of gear teeth.
 Digits must be substituted for both "xx" and "yy" when ordering.

Summary

Under normal conditions, it should not be necessary to change the original calibration of a Turbo-Meter unless it becomes necessary to replace an accuracy sensitive part. Accuracy sensitive parts for the Mark II are the rotor and internal housing. Accuracy sensitive parts for the Auto-Adjust Turbo-Meter are the main rotor, sensing rotor, centerplate, main rotor carrier and sensing rotor carrier. The meter must be calibrated after an accuracy sensitive part is changed. Mechanical friction components such as shafts, bearings, gears and brackets can be changed without recalibration as long as minimum spin time levels are achieved.

It is necessary to maintain good records on the calibration data of each large volume meter. The original units purchased are each shipped with a calibration curve on which the actual accuracy of that specific meter is precisely defined. These original records should be held on file along with any subsequent calibration or spin time data developed for that meter.

805 Liberty Boulevard
 DuBois, PA 15801
 800-375-8875
 Fax: (814) 375-8460
www.sensus.com
 (North American Gas)

For More Information

For more information on Sensus Turbo-Meters, please request the following literature from your Sensus representative.

2" and 3" TPL-9 and T-10HP Turbo-Meters

Bulletin Number	Description
M-1080	General Description of TPL-9 Turbo-Meter
MP-1080B	2" and 3" TPL-9 Parts List
MM-1080	Installation and Maintenance Instructions for TPL-9
M-1083	General Description of T-10 Turbo-Meter
MM-1081	Safety Interlock Device for TPL-9
MP-1081	Safety Interlock Parts List for TPL-9
M-1083	General Description of T-10
M-1083-10	T-10 w/Slot Sensor
MP-1083	2" and 3" T-10 Parts List

4" – 6" – 8" and 12" Mark II Turbo Meters 4" – 6" – 8" and 12" Auto Adjust II Turbo-Meters

Bulletin Number	Description
M-70	General Description of Mark-II and Turbo Meters
M-1073	General Description of Auto-Adjust Turbo-Meters
MP-1070A	4" T-18 and T-27 Turbo-Meter Parts List
MP-1073E	4" AAT-18 and AAT-27 Turbo-Meter Parts List
MP-1070B	6" T-35 and T-57 Turbo-Meter Parts List
MP-1073B	6" AAT-35 and AAT-57 Turbo-Meter Parts List
MP-1070C	8" T-60 and T-90 Turbo-Meter Parts List
MP-1073C	8" AAT-60 and AAT-90 Turbo-Meter Parts List
MP-1070D	12" T-140 and T-230 Turbo-Meter Parts List
MP-1073D	12" AAT-140 and AAT-230 Turbo-Meter Parts List
MP-1070-10	Mark-II with Slot Sensor Pulser or Blade Tip Sensor
MIM-1073	Auto-Adjust II Construction and Design Features

**Representatives
 in all principal cities.**

**Distributors
 throughout the world.**

Authorized Distributor:

Limited Warranty

Seller warrants the Goods to be free from defects in materials manufactured by Seller and in Seller's workmanship for a period of **(one(1) year)** after tender delivery (the "Warranty Period"). **THIS LIMITED WARRANTY**

- (A) IS IN LIEU OF, AND SELLER DISCLAIMS AND EXCLUDES, ALL OTHER WARRANTIES, STATUTORY, EXPRESS OR IMPLIED, INCLUDING, WITHOUT LIMITATION, ANY WARRANTY OF MERCHANTABILITY OR FITNESS FOR A PARTICULAR PURPOSE, OR OF CONFORMITY TO MODELS OR SAMPLES;**
- (B)** does not apply to any Goods which have been (I) repaired, altered or improperly installed; (II) subjected to improper use or storage; (III) used or incorporated with other materials or equipment, after Buyer or anyone using the Goods has, or reasonably should have, knowledge of any defect or nonconformance of the Goods; or (IV) manufactured, fabricated or assembled by anyone other than the Seller;
- (C)** shall not be effective unless Buyer notifies Seller in writing of any purported defect or nonconformance within **(thirty (30) days)** after Buyer discovers or should have reasonably discovered such purported defect or nonconformance; and
- (D)** shall only extend to Buyer and not to any subsequent buyers or users of the Goods. Buyer shall provide Seller access to the Goods as to which Buyer claims a purported defect or nonconformance; upon request by Seller, Buyer shall, at its own risk and expense, promptly return the Goods in question to Seller's Plant.