



Parts List
8" AAT-60 and AAT-90 Auto-Adjust® II Turbo-Meters
w/ Blade Tip Sensors

Parts List
8" AAT-60 and AAT-90
Auto-Adjust® II Turbo-Meters
w/ Blade Tip Sensors

WORKING PRESSURES:
175, 275, 720, 1440 psi

8" AAT-60 and AAT-90 Auto-Adjust® II Turbo-Meters w/ Blade Tip Sensors

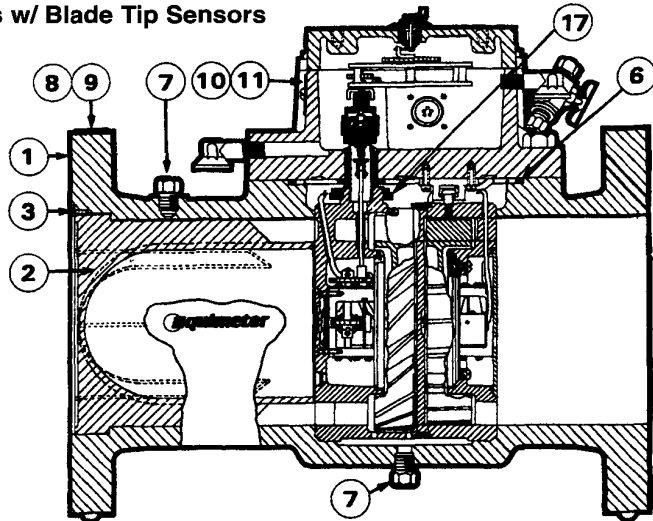
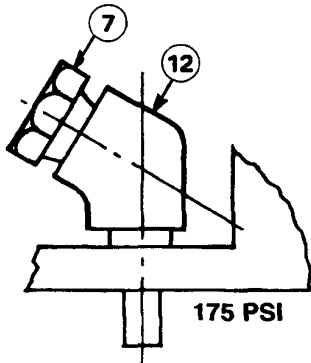
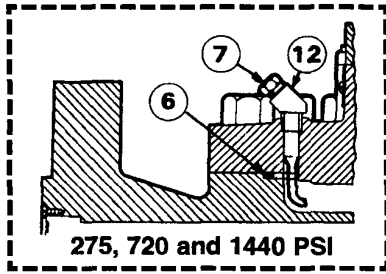

GENERAL ASSEMBLY AAT-60 AND AAT-90 AUTO-ADJUST® II TURBO-METERS W/ BLADE TIP SENSORS

Common abbreviations found in this parts list:

- | | |
|-----------------------------|--------------------------------|
| BTS = Blade Tip Sensor | 1S = One Sensing Rotor Sensor |
| 1M = One Main Rotor Sensor | 2S = Two Sensing Rotor Sensors |
| 2M = Two Main Rotor Sensors | AR = As Required |

NOTE: "HP" designates 275, 720, and 1440 working pressure.

Body Assembly Components

ILLUSTRATION NUMBER	QUANTITY REQUIRED	PART DESCRIPTION	PART NUMBER
1	1	Main Body Assembly, Aluminum, 175# W.P., With Badges Less Nose Cone	006-26-611-20
		Main Body Assembly, Cast Steel, 275# W.P., ANSI 150 With Badges Less Nose Cone	006-26-611-21
		Main Body Assembly, Cast Steel, 720# W.P., ANSI 300 With Badges Less Nose Cone	006-26-611-60
		Main Body Assembly, Cast Steel, 1440# W.P., ANSI 600 With Badges Less Nose Cone	006-26-611-90
		Main Body Assembly, Cast Steel, 1440# W.P., ANSI 600 With Badges Less Nose Cone With Ring Joint Flanges	006-26-611-91
2	1	Nose Cone With Straightening Vanes, All W.P.	006-26-305-21
3	3	#8-32 x 3/8" Long Truss Head, Stainless Steel Machine Screw	950426
4	1	Manufacturer Nameplate, 175# W.P., AAT-60 (not shown)	006-26-073-20-555
		Manufacturer Nameplate, 275# W.P., AAT-60 (not shown)	006-26-073-30-555
		Manufacturer Nameplate, 720# W.P., AAT-60 (not shown)	006-26-073-60-555
		Manufacturer Nameplate, 1440# W.P., AAT-60 (not shown)	006-26-073-90-555
		Manufacturer Nameplate, 175# W.P., AAT-90 (not shown)	006-46-073-20-555
		Manufacturer Nameplate, 275# W.P., AAT-90 (not shown)	006-46-073-30-555
		Manufacturer Nameplate, 720# W.P., AAT-90 (not shown)	006-46-073-60-555
Manufacturer Nameplate, 1440# W.P., AAT-90 (not shown)	006-46-073-90-555		
5	4	Manufacturer Nameplate Drive Screws, #4 x 3/16" Long Round Head Brass Drive Screw	903004
6	1	Top Plate to Body "O" Ring, 175# W.P., Buna-N	934352
		Top Plate to Body "O" Ring, 175# W.P., Viton-A (Optional)	906745
		Top Plate to Body "O" Ring, 275#, 720#, 1440# W.P., Buna	950191
		Top Plate to Body "O" Ring, 275#, 720#, 1440# W.P., Viton (Optional)	906746
7	3	1/4"-18 Steel Pipe Plug	906055
8	1	Inlet Badge (On Inlet Flange of Body)	015-16-090-02
9	2	Inlet Badge Drive Screw, #2 x 1/8" Round Head Brass	903003
10	1	Meter Factor Badge (On Top Plate) FT ³	006-32-073-10
		Meter Factor Badge (On Top Plate) M ³	006-32-073-11
11	2	#8-32 x 1/4" Long Round Head Brass Machine Screw	903055
12	1	45° Steel Elbow 1/4" Male to Female for 275#, 720# and 1440#	950762
13	1	Internal Mechanism Badge, AAT-60 (not shown)	006-36-073-02
		Internal Mechanism Badge, AAT-90 (not shown)	006-46-073-02
14	4	#0 x 1/8" Long Drive Screw (not shown)	903001
15	1	C.S.A. Manufacturer Nameplate, AAT-60 (not shown)	006-36-074-00
		C.S.A. Manufacturer Nameplate, AAT-90 (not shown)	006-46-074-00
16	4	Drive Screw for C.S.A. Nameplate (not shown)	903003
*17	1	Seal, Buna-N	904076

*Recommended Spare Parts

LUBRICATION SYSTEM FITTINGS

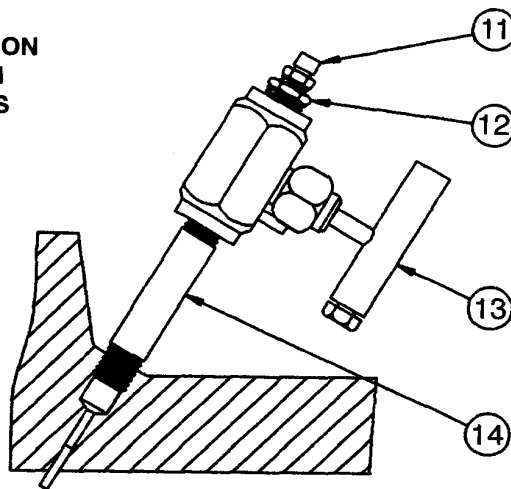

External Lubrication System Fittings

ILLUSTRATION NUMBER	QUANTITY REQUIRED	PART DESCRIPTION	PART NUMBER
11	1	Lubrication Gun Fitting	006-24-145-00
12	1	Hex Bushing, 1/4" to 1/8" Steel	950195
13	1	Valve, 1/4" Carbon Steel	950710
14	1	Pipe Nipple, 1/4" x 3" Steel	950760

INDEX SHAFT AND GLAND ASSEMBLY

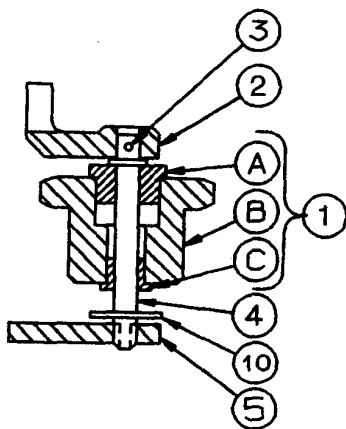

INDEX PLATE ASSEMBLY

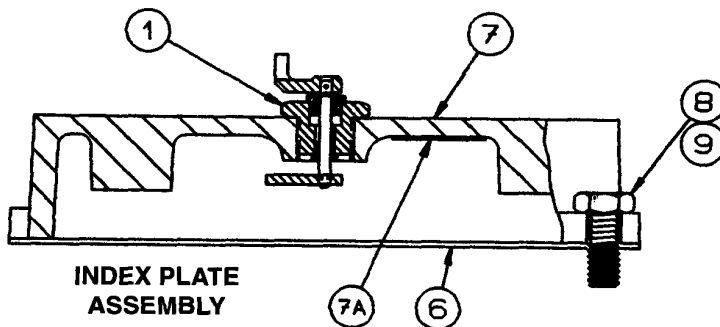

Index Plate Assembly Components

ILLUSTRATION NUMBER	QUANTITY REQUIRED	PART DESCRIPTION	PART NUMBER
1	1	Index Shaft Gland Assembly (Includes illustration Nos. 1A-C)	006-24-323-00
1A	1	Gland	006-24-023-01
1B	1	Bushing (Top)	006-24-052-01
1C	1	Bushing (Bottom)	001-60-052-62
2	1	Top Index Shaft Dog	006-24-061-04
*3	1	Shear Pin, Top Index Shaft Dog	006-24-056-00
4	1	Index Shaft	006-24-054-02
5	1	Bottom Index Shaft Dog	006-24-071-00
*6	1	Gasket, Index Plate to Top Plate	006-24-160-03
7	1	Index Plate	006-24-004-21
7A	1	Wiring Label (BTS)	006-51-105-00
8	3	Cap Screw, Index Plate to Top Plate, 5/16"-18 x 3/4" Hex Head Steel Grade 5	910028
9	1	Seal Screw, Index Plate to Top Plate, 5/16"-18 x 3/4" Hex Head Steel Grade 5	002-65-057-02
10	1	Retaining Ring	950578

*Recommended Spare Parts

8" AAT-60 and AAT-90 Auto-Adjust® II Turbo-Meters w/ Blade Tip Sensors

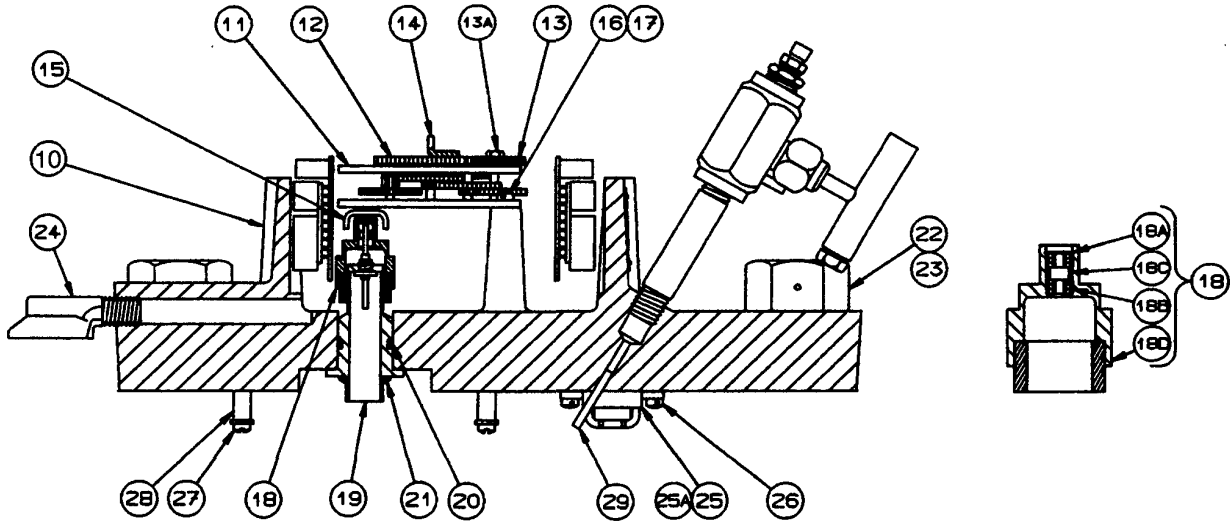

Top Plate Assembly - Mechanical Components

ILLUSTRATION NUMBER	QUANTITY REQUIRED	PART DESCRIPTION	PART NUMBER
10	1	Top Plate Assembly, Aluminum, 175# W.P.	006-36-303-20
	1	Top Plate Assembly, Cast Steel, 275# W.P.	006-36-303-31
	1	Top Plate Assembly, Cast Steel, 720# W.P.	006-36-303-91
	1	Top Plate Assembly, Cast Steel, 1440# W.P.	006-36-303-91
11	1	Intermediate Gear Assembly, 1000 CF/Rev. Output, Less Change Gears	006-34-212-20
	1	Intermediate Gear Assembly, 10M ³ /Rev. Output, Less Change Gears	006-36-212-40
12	1	Large Change Gear (Note: "XX" Refers to Gear Blank (Diameter) Size, "YY" Refers to Number of Gear Teeth. Digits Must Be Substituted for "XX" and "YY" When Ordering.)	006-24-3XX-YY
13	1	Small Change Gear (See Note for Illustration No. 12 Above)	006-24-3XX-YY
13A	1	Small Change Gear Nut, #4-40 Hex Stainless Steel	907639
14	1	Intermediate Gear Output Dog (Top)	002-66-071-03
15	1	Intermediate Gear Input Dog (Bottom)	006-24-061-40
16	3	Intermediate Gear Retaining Screw, #8-32 x 3/8" Long Fillister Head Screw	903371
17	3	#8 External Lockwasher, Stainless Steel	950371
*18	1	Follower Magnet Assembly (Includes Illustration Nos. 18 A-D)	006-24-313-20
18A	1	Retaining Ring	904691
*18B	2	Bearing	905462
18C	1	Spacer	006-24-106-20
18D	1	Follower Magnet Holder Assembly With Magnet	006-24-213-20
*19	1	Magnet Well and Post Assembly, 175# & 275# W.P. (Includes Illustration No. 20)	006-24-244-20
		Magnet Well and Post Assembly, 720# & 1440# W.P. (Includes Illustration No. 20)	006-26-244-90
*20	1	Magnet Well "O" Ring, Buna	950193
		Magnet Well "O" Ring, Viton (Optional)	908264
*21	1	Magnet Well Seal, Buna	904214
		Magnet Well Seal, Viton (Optional)	906736
22	11	Cap Screw, Top Plate to Body, 175# W.P., 1/2"-13 x 1-3/4" Long Hex Head Steel Grade 5	910108
		Cap Screw, Top Plate to Body, 275# W.P., 1/2"-13 x 1-1/2" Long Hex Head Steel Grade 8	950065
		Cap Screw, Top Plate to Body, 720# & 1440# W.P., 7/8"-9 x 2-3/4" Long Hex Head Steel Grade 8	907511
23	1	Seal Cap Screw, Top Plate to Body, 175# W.P., 1/2"-13 x 1-3/4" Long Hex Head Steel Grade 5	006-26-056-00
		Seal Cap Screw, Top Plate to Body, 275# W.P., 1/2"-13 x 1-1/2" Long Hex Head Steel Grade 8	006-26-056-01
		Seal Cap Screw, Top Plate to Body, 720# & 1440# W.P., 7/8"-9 x 2-3/4" Long Hex Head Steel Grade 8	006-26-057-91
24	2	Vent Cap Assembly	006-24-505-01
25A	1	Extractor Bracket	006-34-089-01
25B	1	Spring Clip	006-41-089-00
26	2	Extractor Bracket Screw, #8-32 x 1/2" Long Fillister Head Stainless Steel Machine Screw	903373
27	2	Adapter Plate Screw, #8-32 x 7/8" Long Fillister Head	906847
28	2	Adapter Plate Bushing	006-32-113-01
29	1	1/8"-Aluminum Tubing For Oil System, Unformed	51911

*Recommended Spare Parts

COUPLING SHAFT AND DRIVER MAGNET COMPONENTS

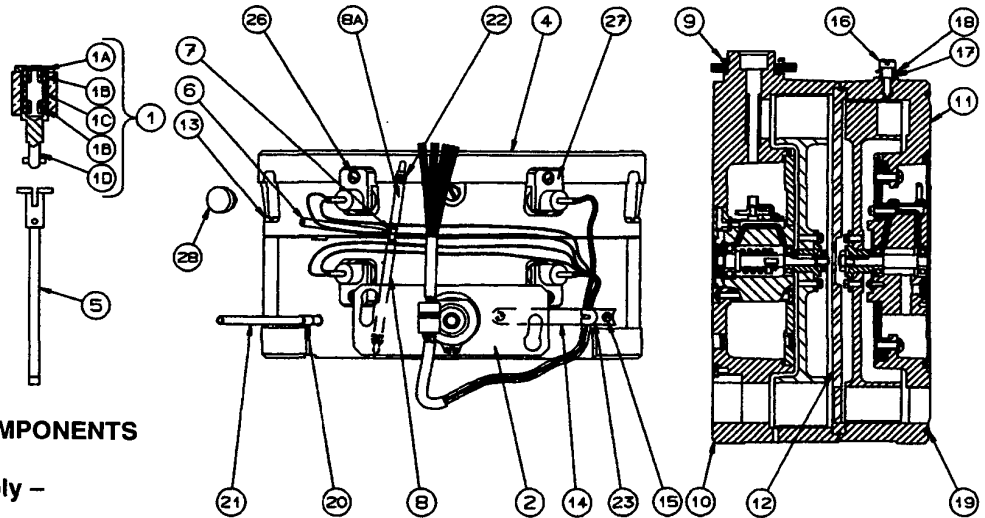

INTERNAL HOUSING COMPONENTS

Internal Housing Assembly – Mechanical Components

ILLUSTRATION NUMBER	QUANTITY REQUIRED	PART DESCRIPTION	PART NUMBER
*1	1	Magnet Holder and Bearing Assembly (Includes Illustration Nos. 1 A-C)	006-31-334-00
1A	1	Retaining Ring	904691
*1B	2	Bearing	905462
1C	1	Spacer	006-22-106-03
1D	1	Magnet Holder & Pin Assembly	006-31-234-02
2	1	Adapter Plate	006-32-062-01
4	1	Buna 1M/1S Internal Housing Assembly, Calibrated With Change Gears, 175# W.P., Cubic Foot	AAT-60 006-36-302-16
		Internal Housing Assembly, Calibrated With Change Gears, 175# W.P., Metric	AAT-60 006-36-302-17
		Internal Housing Assembly, Calibrated With Change Gears, High Pressure, Cubic Foot	AAT-60 006-36-302-19
		Internal Housing Assembly, Calibrated With Change Gears, High Pressure, Metric	AAT-60 006-36-302-20
		Internal Housing Assembly, Calibrated With Change Gears, 175# W.P., Cubic Foot	AAT-90 006-46-302-16
		Internal Housing Assembly, Calibrated With Change Gears, 175# W.P., Metric	AAT-90 006-46-302-17
		Internal Housing Assembly, Calibrated With Change Gears, High Pressure, Cubic Foot	AAT-90 006-46-302-19
5	1	Coupling Shaft Assembly, 175# and 275# W.P.	006-36-345-20
		Coupling Shaft Assembly, 720# and 1440# W.P.	006-36-345-90
6	1	Oil Tubing, Top Plate to Internal Housing	99993
7	1	Tee, 1/8" Polypropylene	950247
8	1	Oil Tubing, Tee to Metering Rotor Module	99993
8A	1	Oil Tubing, Tee to Sensor Rotor Module	99993
9	1	Retaining Ring	904435
**10	1	Main (Metering) Rotor Assembly (AAT-60) Buna 1BTS	006-36-550-05
		Main (Metering) Rotor Assembly (AAT-90) Buna 1BTS	006-46-550-05
**11	1	Sensing Rotor Assembly (AAT-60) Buna 1BTS	006-36-550-06
		Sensing Rotor Assembly (AAT-90) Buna 1BTS	006-46-550-06
**12	1	Center Plate (AAT-60)	006-36-109-01
		Center Plate (AAT-90)	006-46-109-01
13	2	Module Connecting Screws, #10-24 x 3/4" Long Stainless Steel Machine Screw NOTE: Maximum Torque = 24 Inch/Lb.	950384
14	1	Serial Number Badge	006-34-073-01
15	2	Serial Number Badge Screw, #4-40 x 1/4" Long Pan Head Stainless Steel Machine Screw	950380
16	1	Shoulder Screw, 1/4" x 1/4" Stainless Steel	950319
17	1	"O" Ring, Buna	934005
		"O" Ring, Viton	904839
18	1	Disc Spring	950749
19	1	Seal, Viton	950708
20	2	Compression Ring (Pressure Tubing) AAT-60	950772
21	1	Pressure Tubing AAT-60	800700
22	3	Compression Ring (Lube Tubing)	950682
23	1	Wire Clip	950517
25	1	Oil Tube Replacement Assembly (Not Shown) (Includes 6, 7, 8, 8A & 22)	006-36-325-00
26	AR	8-32 x 3/8" Long Fillister Head Screw	903371
27	AR	Sensor Clip	006-51-041-02
28	AR	Sensor Plug	006-51-043-01

* Recommended Spare Parts

** Illustration Nos. 10, 11, and 12 affect calibration. These components must be ordered in combination and cannot be supplied as separate items.

8" AAT-60 and AAT-90 Auto-Adjust® II Turbo-Meters w/ Blade Tip Sensors
MAIN (METERING) ROTOR ASSEMBLY COMPONENTS

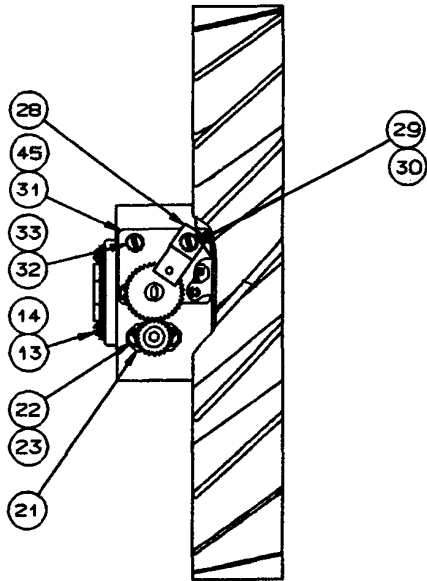

**TOP VIEW
 BEARING BRACKET**

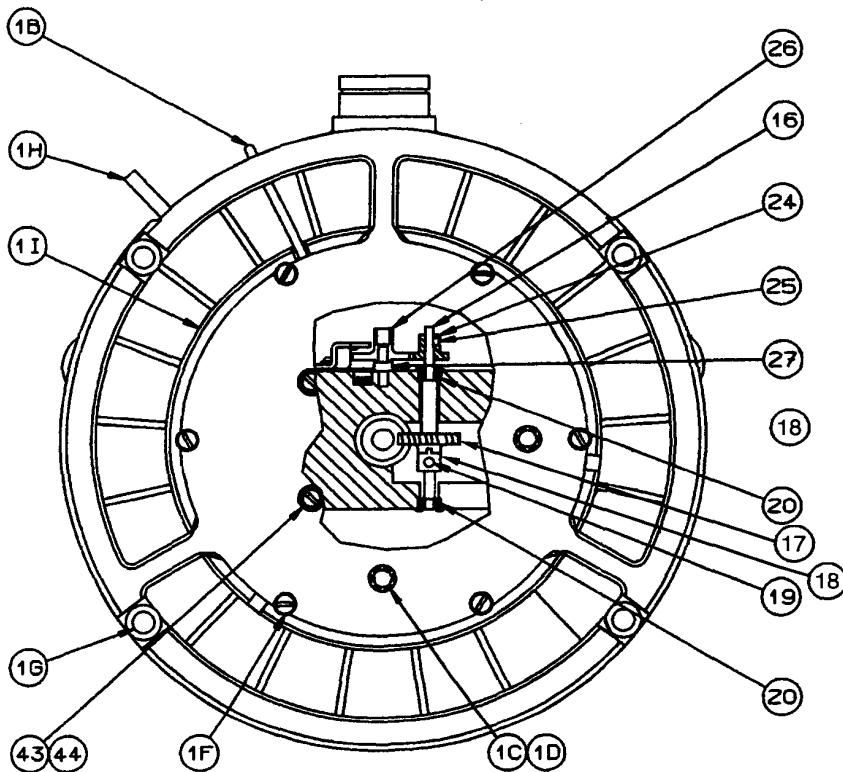

INLET VIEW

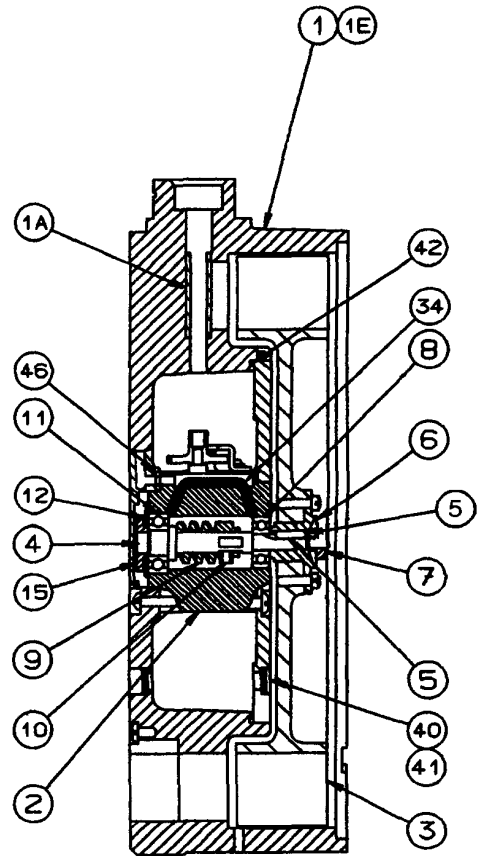

SIDE VIEW



Main Rotor Assembly Components

ILLUSTRATION NUMBER	QUANTITY REQUIRED	PART DESCRIPTION	PART NUMBER
**	1	Main (Metering) Rotor Assembly, Buna, 1 BTS, AAT-60	006-36-550-05
		Main (Metering) Rotor Assembly, Buna, 1 BTS, AAT-90	006-46-550-05
**1	1	Carrier Assembly (Includes Illustration Nos. 1 A-I)	006-36-519-04
1A	1	Coupling Shaft Shield Tube	006-36-082-01
1B	1	Oil Tubing, Aluminum	006-34-079-01
1C	2	Filter Screen, Stainless Steel	006-22-083-01
1D	2	Screen Retainer	904419
**1E	1	Bearing Bracket Carrier	006-36-019-06
1F	6	#6-32 x 1/4" Pan Head Stainless Steel Machine Screw	950585
1G	4	Module Seal Positioner	950756
1H	1	Pressure Tap Tube, Aluminum, AAT-60	006-34-079-02
1I	3	Vane Insert	006-36-025-00
2	1	Bearing Bracket	006-36-209-02
**3	1	Rotor and Insert Assembly, AAT-60	006-36-350-02
		Rotor and Insert Assembly, AAT-90	006-46-350-02
4	1	Main Rotor Shaft	006-36-024-02
5	1	Locking Pin, Rotor to Shaft	006-24-069-00
6	1	Spherical Washer	006-36-077-00
7	1	Locknut	906180
*8	1	Downstream Rotor Shaft Bearing	950277
9	1	Worm	006-34-017-00
10	2	Retaining Screw, Worm to Shaft, #4-40 x 1/8" Long Hex Head Stainless Steel Set Screw, Nylon Locking	950305
*11	1	Upstream Rotor Shaft Bearing	906019
12	1	Upstream Bearing Retainer Plate	006-36-117-00
13	3	#3-48 x 5/16" Long Round Head Stainless Steel Machine Screw	903013
14	3	Lockwasher, #3 Stainless Steel	950372
15	1	Retaining Nut, Main Rotor Shaft	006-36-084-00
16	1	Wormwheel Shaft	006-24-046-20
17	1	Wormwheel (15T)	006-24-035-00
18	1	Wormwheel (Hub)	006-24-070-02
19	2	Set Screw, #6-32 x 1/8" Long Stainless Steel Nylon Locking	950375
*20	2	Bearing	908660
21	2	Bearing Retainer Plate	006-22-117-01
22	4	#4-40 x 1/4" Long Pan Head Stainless Steel Machine Screw	950380
23	4	#4 External Lockwasher, Stainless Steel	950078
24	1	17T Idler Gear, AAT-60	006-26-317-17
		23T Idler Gear, AAT-90	006-36-317-23
25	1	Idler Gear Set Screws, #6-32 x 1/8" Long Stainless Steel Nylon Locking	950375
26	1	44T Drive Gear, AAT-60	006-36-444-44
		38T Drive Gear, AAT-90	006-46-444-38
27	1	Gear Post	006-31-028-00
28	1	Gear Retainer	006-24-080-00
29	1	#4-40 x 1/4" Long Pan Head Stainless Steel Machine Screw	950380
30	1	Lockwasher, #4, Stainless Steel	950078
31	1	Oil Reservoir Cover	006-36-053-00
32	1	#4-40 x 1/4" Long Pan Head Stainless Steel Machine Screw	950380
33	1	Lockwasher, #4, Stainless Steel	950078
34	1	Oil Wick, .09" x .09"	1191430
40	1	Filter Screen, Stainless Steel	006-22-083-01
41	1	Filter Screen Retainer	904419
42	1	Bracket to Carrier Seal	950424
43	4	#6-32 x 1/2" Long Round Head Stainless Steel Machine Screw	950373
44	4	Lockwasher, #6 Stainless Steel	950144
45	1	Oil Reservoir Gasket	006-36-160-07
46	1	Seal, Oil Passage	006-36-160-09

* Recommended Spare Parts

** These items affect calibration and must be ordered in combination with Sensor Assembly, (Center) Plate, and Internal Housing.

8" AAT-60 and AAT-90 Auto-Adjust® II Turbo-Meters w/ Blade Tip Sensors

SENSING ROTOR ASSEMBLY COMPONENTS

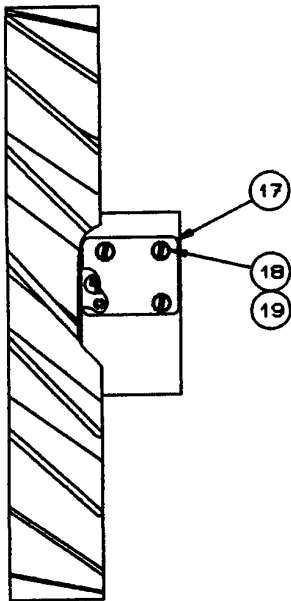

BEARING BRACKET
TOP VIEW

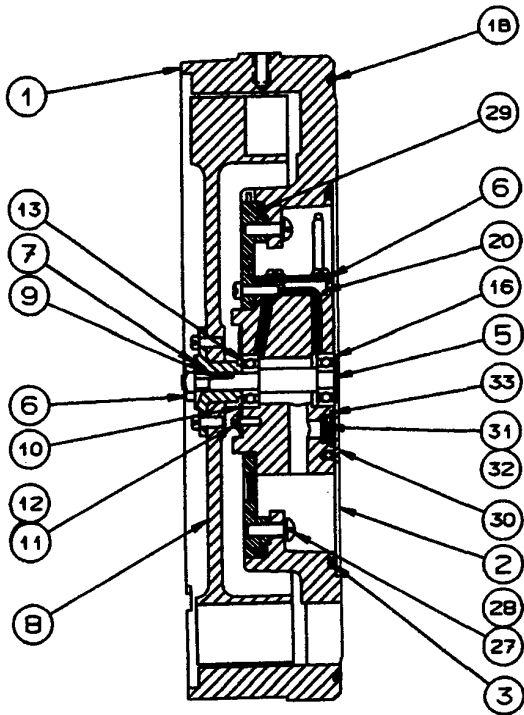

SIDE VIEW

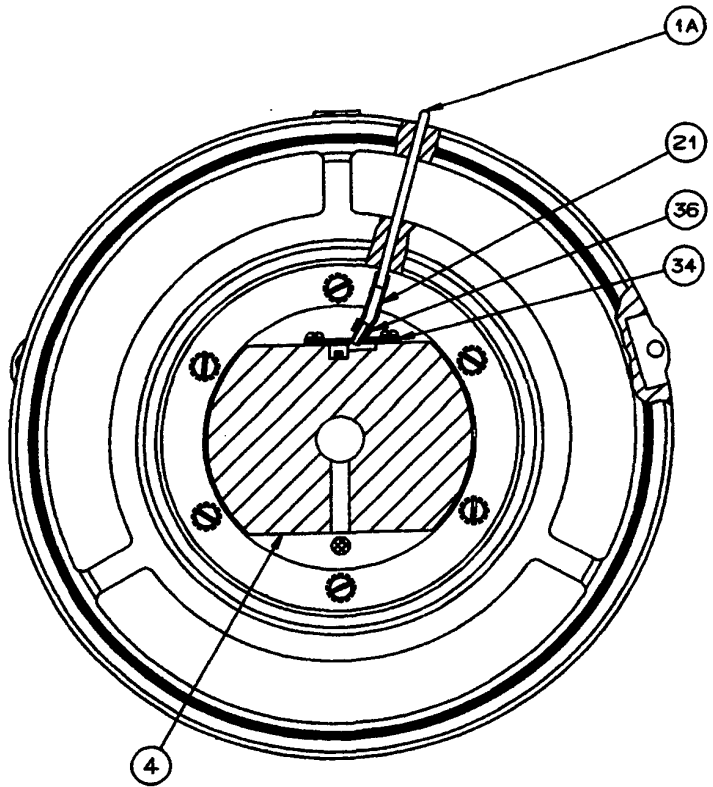

DOWNSTREAM
END VIEW



Sensing Rotor Assembly Components

ILLUSTRATION NUMBER	QUANTITY REQUIRED	PART DESCRIPTION	PART NUMBER
**	1	Sensing Rotor Assembly, Buna, 1 BTS, AAT-60	006-36-550-06
		Sensing Rotor Assembly, Buna, 1 BTS, AAT-90	006-46-550-06
**1	1	Carrier Assembly (Includes Illustration Nos. 1A & B)	006-36-519-05
1A	1	Oil Tube, Aluminum	006-36-079-01
1B	1	Seal, Viton (Held in w/Bostik Adhesive 4585, P/N 905120)	950708
2	1	Housing Plate	006-36-010-00
3	1	Seal	908553
4	1	Bearing Bracket	006-36-221-01
5	1	Rotor Shaft	006-36-024-01
6	1	Locknut	906180
7	1	Spherical Washer	006-36-077-00
**8	1	Rotor and Insert Assembly, AAT-60	006-36-350-01
		Rotor and Insert Assembly, AAT-90	006-46-350-01
9	1	Rotor Locking Pin	006-24-069-00
10	1	Upstream Bearing Retainer Plate	006-36-117-01
11	3	#3-48 x 5/16" Long Round Head Stainless Steel Machine Screw	903013
12	3	#3 Internal Lockwasher, Stainless Steel	950372
*13	1	Upstream Rotor Shaft Bearing	950277
*16	1	Downstream Rotor Shaft Bearing	950277
17	1	Oil Reservoir Cover Assembly	006-36-253-00
18	4	#4-40 x 1/4" Long Pan Head Stainless Steel Machine Screw	950380
19	4	#4 External Lockwasher	950078
20	AR	Oil Wick, .09" x .09"	1191430
21	AR	Tubing for Oiling System	99993
27	6	#8-32 x 1/2" Long Round Head Stainless Steel Machine Screw	908722
28	6	#8 External Lockwasher, Stainless Steel	950371
29	1	Seal, Carrier to Bracket	950278
30	4	#4-40 x 1/4" Long Flat Head Machine Screw	903110
31	2	Filter Screen, Stainless Steel	006-22-083-01
32	2	Screen Retainer	904419
33	1	Seal	950320
34	1	Gasket, Oil Reservoir	006-36-160-08
36	1	Compression Ring, Oil Tubing	950682
		Oil, 4 Ounce Bottle, RFEM	006-22-405-01
		Oil, 1 Gallon Can	006-22-405-02
		Lubrication Hand Gun	006-24-400-00
		Blank Top Plate, 175# W.P.	006-26-003-25
		Blank Top Plate, 275# W.P.	006-26-003-26
		Blank Top Plate, 720#, 1440# W.P.	006-26-003-92

* Recommended Spare Parts

** These items affect calibration and must be ordered in combination with Main Rotor Assembly and Decoupling (Center) Plate.

8" AAT-60 and AAT-90 Auto-Adjust® II Turbo-Meters w/ Blade Tip Sensors

TOP PLATE & INTERNAL HOUSING ASSEMBLY (VIEW FROM DOWNSTREAM)

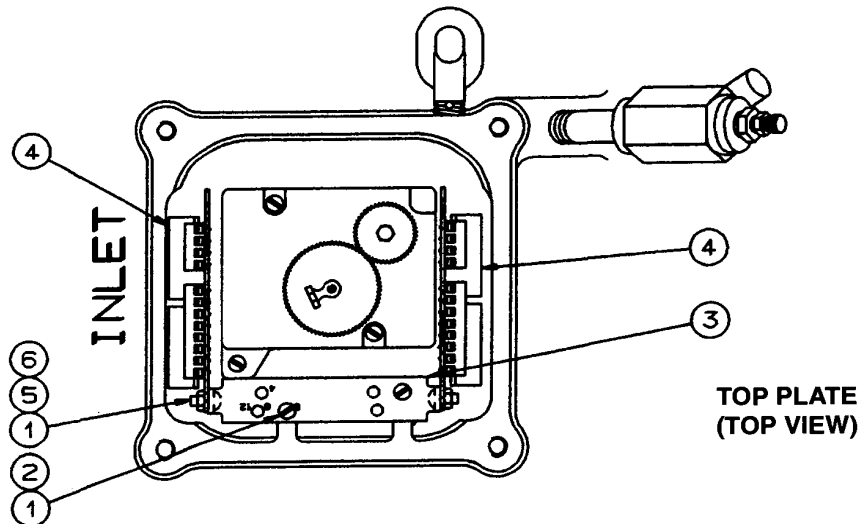
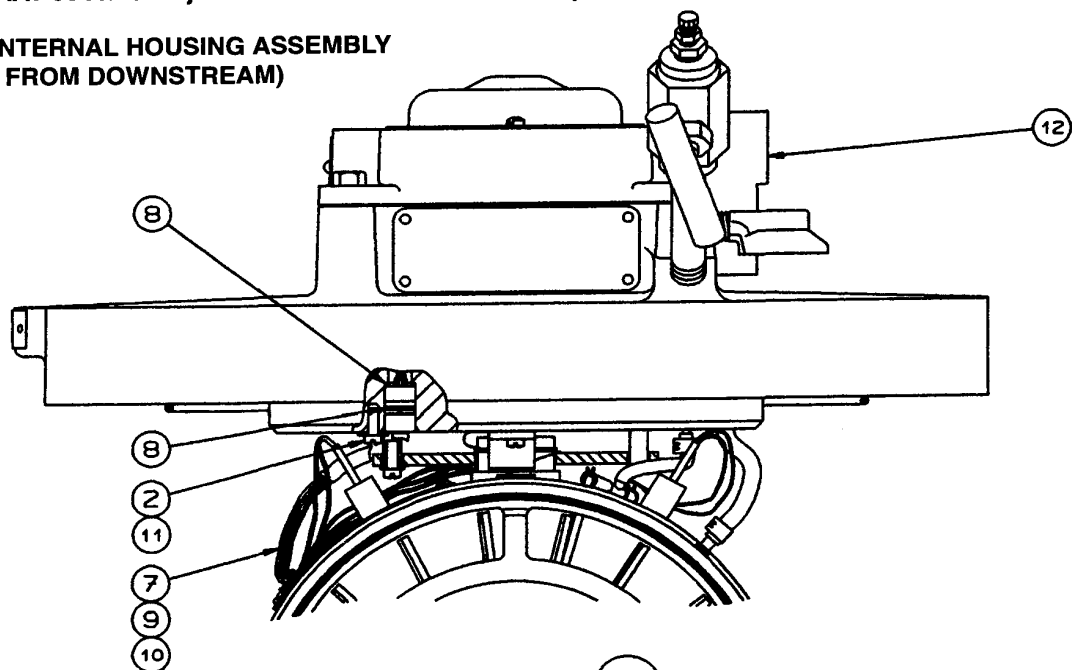

**TOP PLATE
(TOP VIEW)**

Electrical System

ILLUSTRATION NUMBER	QUANTITY REQUIRED	PART DESCRIPTION	PART NUMBER
1	AR	#8 Sta Stl Lockwasher	950371
2	AR	#8-32 x 3/8" Long Stainless Steel Fillister Head Screw	903371
3	1	Signal Conditioner Mounting Bracket	006-51-048-00
4	AR	Dual Channel Signal Conditioner	951232
		Single Channel Signal Conditioner	951233
5	AR	#8-32 Stainless Steel Hex Nut	903924
6	AR	#8-32 x 3/8" Long Stainless Steel Pan Head Screw	950839
7	1	Sensor / Feedthru Assembly Buna 1M/1S	951231
		Sensor / Feedthru Assembly Viton 1M/1S	006-32-317-02
8	AR	O-Ring Viton -40	950774
		O-Ring Buna	946861
9	AR	Shrink Tubing	800633
10	AR	Solder, Bar Form, 50/50, 1/4" dia., 2" pc.	750155
11	1	Regular Washer	950448
12	1	Bendix Connector Manifold	006-51-122-05

Wiring System Components For Blade Tip Sensors

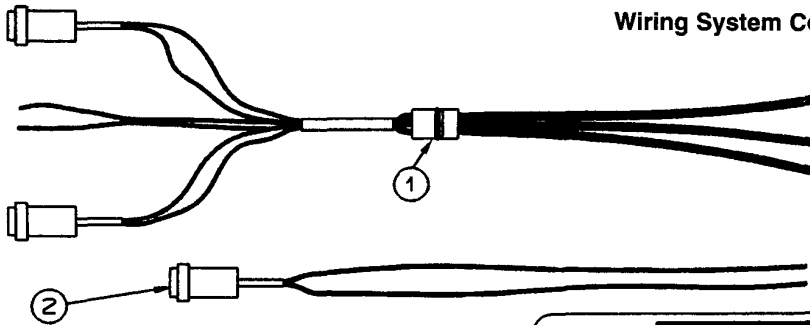

WIRING LABEL

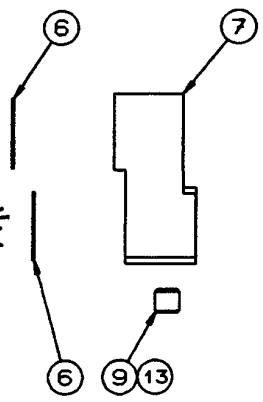
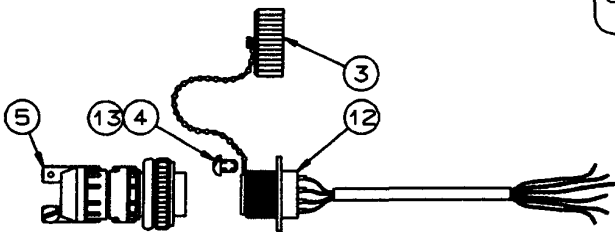
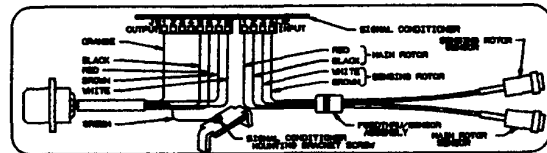

OR

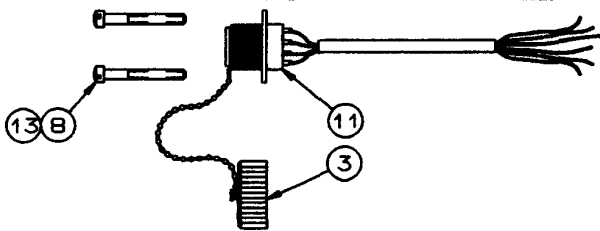

OR

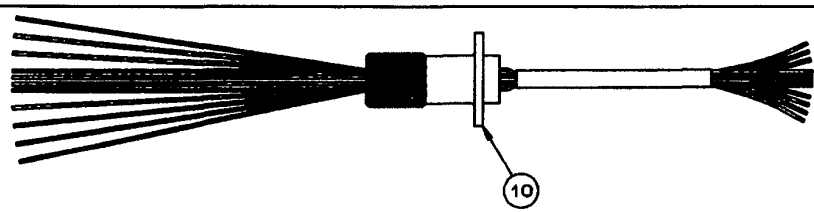

Wire Fittings

ILLUSTRATION NUMBER	QUANTITY REQUIRED	PART DESCRIPTION	PART NUMBER
1	AR	Sensor Feedthru Assembly, Buna 1M/1S (Includes Item 2)	951231
2	AR	Main Rotor Sensor Coil and Wire Assembly (Red/Black Wires)	951237
		Sensing Rotor Sensor Coil and Wire Assembly (White/Brown Wires)	951236
3	AR	Bendix Cap and Chain Assembly	006-32-101-00
4	AR	#8-32 x 1/4" Long Stainless Steel Round Head Screw	903055
5	AR	6 Socket Bendix Cable Connecting Plug	951245
6	AR	Bendix Connector Gasket	905321
7	AR	Bendix Connector Manifold	006-51-122-05
8	AR	#8-32 x 1-1/2" Lg Fillister Head Screw	919711
9	AR	5/16-18 x 3/8" Lg Set Screw	906220
10	AR	Six Wire Conduit Connector Assembly 1M/1S	006-51-330-00
		Eleven Wire Conduit Connector Assembly 1M/2S 2M/1S 2/2S	006-51-330-01
11	AR	Six Wire Bendix Connector Assembly	All Bendix Applications 006-51-101-00
12	AR	Four Wire Bendix Connector Assembly	2 Main/1 Sensing Application 006-51-101-01
		Four Wire Bendix Connector Assembly	1 Main/2 Sensing Applications 006-51-101-02
		Four Wire Bendix Connector Assembly	2 Main/2 Sensing Applications 006-51-101-03
13	AR	Thread Locking Agent	905115



805 Liberty Boulevard
DuBois, PA 15801
814-375-8875
Fax 814-375-8460

Authorized Distributor

Limited Warranty

Seller warrants the Goods to be free from defects in materials manufactured by Seller and in Seller's workmanship for a period of one (1) year after tender of delivery (the "Warranty Period"). THIS LIMITED WARRANTY (a) IS IN LIEU OF, AND SELLER DISCLAIMS AND EXCLUDES ALL OTHER WARRANTIES, STATUTORY, EXPRESS OR IMPLIED, INCLUDING, WITH LIMITATION, ANY WARRANTY OF MERCHANTABILITY OR FITNESS FOR A PARTICULAR PURPOSE, OR OF CONFORMITY TO MODELS OR SAMPLES; (b) does not apply to any Goods which have been (i) repaired, altered or improperly installed; (ii) subjected to improper use or storage, (iii) used or incorporated with other materials or equipment, after buyer or anyone using the Goods has, or reasonably should have, knowledge of any defect or nonconformance of the Goods; or (iv) manufactured, fabricated or assembled by anyone other than Seller, (c) shall not be effective unless buyer notifies Seller in writing of any purported defect or nonconformance with (thirty days) after Buyer discovers or should have reasonably discovered such purported defect or nonconformance; and (d) shall only extend to Buyer and not to any subsequent buyers or users of the Goods. Buyer shall provide Seller access to the Goods as to which Buyer claims a purported defect or nonconformance, upon request by Seller, buyer shall, at its own risk and expense, promptly return the Goods in question to Seller's Plant.