



Regulator Installation and Maintenance Instructions, and Parts List

046 Field Regulators

Simple design, rugged construction and top performance make these regulators a dependable, economical answer for a wide variety of pounds to pounds applications. They are also available with an internal relief valve (IRV) and with a stem seal and control line tap for use as the upstream regulator in a monitor set.

The 046 Regulators are typically used for farm taps, field regulator applications, propane tanks and high pressure industrial air or gas uses.

Maximum Inlet Pressure 046, 046-M & 046C Models

Orifice	SPRINGS		
	Yellow	Aluminum, White, Tan, Dark Green	Gray
1/8"	500 psi	1000 psi	1000 psi
3/16"	500 psi	1000 psi	1000 psi
1/4"	500 psi	500 psi	500 psi
5/16"	300 psi	400 psi	400 psi
3/8"	300 psi	300 psi	400 psi
1/2"	100 psi	100 psi	100 psi

Inlet Pressuresto 1000 psi
 Outlet Pressures3 to 200 psi
 Pipe Sizes3/4", 1", and 1 1/4"

Maximum Inlet Pressure 046-2 & 046-2M Models

Orifice	SPRINGS	
	Yellow	Aluminum, White, Tan, Dark Green
1/8"	500 psi	925 psi
3/16"	500 psi	925 psi
1/4"	500 psi	500 psi
5/16"	300 psi	400 psi
3/8"	300 psi	300 psi
1/2"	100 psi	100 psi

Inlet Pressuresto 925 psi
 Outlet Pressures3 to 125 psi
 Pipe Sizes3/4", 1", and 1 1/4"

Maximum Inlet Pressure 046-PL & 046-CPL Models

Orifice	SPRINGS	
	Yellow	Aluminum
1/8" to 1/2"	250 psi	250 psi

Inlet Pressuresto 250 psi
 Outlet Pressures5 to 100 psi
 Pipe Sizes3/4", 1", and 1 1/4"

Valve Material	Max Inlet Pressure	Max Diff. Pressure
Poly-U Tan (90 duro)	1000 psig	800 psig
Buna-N (80 duro)	525 psig	400 psig
Viton (70 duro)	300 psig	250 psig

Installation and Start-Up

- 1 Remove the shipping plugs from both the regulator inlet and outlet connections.
- 2 Make certain that the inside of the piping and the regulator inlet and outlet connections are clean—they must be free of dirt, pipe dope and other debris.
- 3 Use pipe joint material only on the male threads of the pipe being connected to the regulator. Do not use pipe joint material on the female threads of the regulator.
- 4 Install the regulator in the line. Make certain that the gas flow through the regulator is in the direction indicated by the arrow on the regulator body.

The regulator may be installed in any position: right side up, upside down, vertical piping, diagonal piping, etc. If required, the diaphragm case may be rotated 360° in any number of increments. To rotate diaphragm case assembly to another position in relation to the body, loosen coupling nut (33). Make certain it is retightened to 35 to 50 Ft.-Lb. to hold the diaphragm case assembly in the new position and to reseal.

The diaphragm case vent must be positioned to protected against flooding, drain water, ice formation, traffic, tampering, etc. The vent must be protected against nest building animals, bees, insects, etc. to prevent vent blockage and to minimize the chances of foreign material collecting in the vent side of the regulator diaphragm.

CAUTION
<i>Turn gas on very slowly. If an outlet stop valve is used, it should be opened first. Do not overload the diaphragm with a sudden surge of inlet pressure. Monitor the outlet pressure during start-up to prevent an outlet pressure overload.</i>

- 5 Turn gas on very slowly.
- 6 Make certain that there are no leaks and that all connections are tight.
- 7 Adjust set-point (outlet pressure) by turning adjustment screw (58). Turn clockwise to increase and counterclockwise to decrease. Be sure to tighten nut (57) after adjustment is completed. Do not adjust when regulator is closed (no flow). Only adjust when gas is flowing through regulator (approximately 250 SCFH).

Except for lock-up (regulator closed), the outlet pressure during normal operation must not go higher than the maximum limit of the spring range. Whenever it goes

(Continued on page 2)

Model	Body	Diaphragm Case	Internal Relief Valve	Maximum Inlet Pressure	Outlet Pressure Range
046 046-M' 046-C	Ductile Iron ASTM 395 GR 60-90-18	Aluminum Aluminum Cast Iron	No No No	SEE TABLES ABOVE	3 to 200 psi
046-2 046-2M'		Aluminum Aluminum	Yes Yes		3 to 125 psi
046-PL 046-CPL		Aluminum Cast Iron	No No		5 to 100 psi

1. Regulator requires a control line

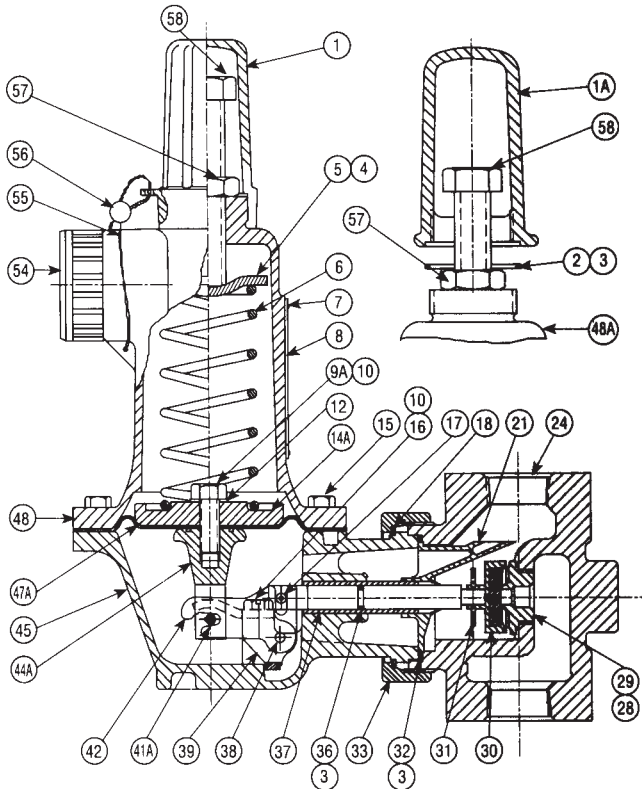

MODEL NO. 046

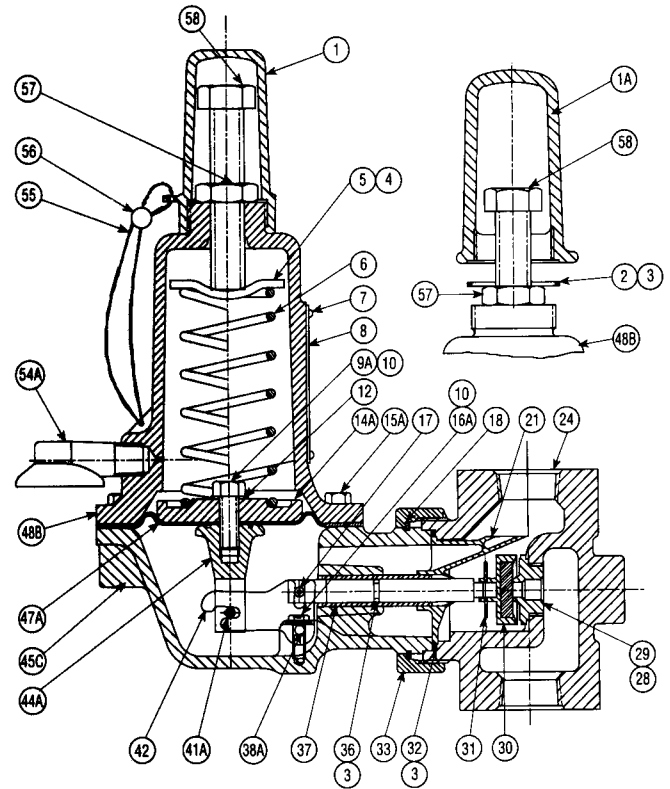

MODEL NO. 046-C

higher, the spring could be overstressed. Also, the higher pressure springs could compress solid and thereby keep the regulator from closing.

Therefore, whenever the set-point is within the upper third of the spring range, set-point adjustment should be made at low flow (approximately 250 SCFH). If set-point adjustment must be made when flow is greater, use the next higher range spring.

CAUTION

It is the user's responsibility to assure that all regulator vents and/or vent lines exhaust to a non-hazardous location away from any potential sources of ignition. Where vent lines are used, it is the user's responsibility to assure that each regulator is individually vented and that common vent lines are not used.

8 The vent assembly (54) or (54A) is an escape path for flammable gas and it must be located and/or piped so that potential discharge occurs in a safe area away from buildings, open flames, collection areas, arcing devices, etc.

Regulators that are installed indoors or in a non-vented area must be vented to the outside. Simply run vent piping from the regulator vent connection to a non-hazardous location on the outside away from any potential sources of ignition. The vent piping must be a minimum 1/4 NPT, connection size or larger and piped to a safe area. The vent discharge must be protected against the potentials outlined in instructions #4, #8, #9, and #10.

For regulators equipped with internal relief valves (IRV), models 046-2 and 046-2M, vent piping must be vent connection size (1" NPT) or larger. This will assure that the vent piping will be large enough to be able to vent all of the internal relief valve discharge to atmosphere without excessive back pressure that would result in excessive pressure increase in the regulator.

The outlet of the vent piping must allow for the free and unobstructed passage of air and gas and must be protected against the potentials listed in instructions #4, #8, #9, and #10.

9 For outdoor installations, it is recommended that the regulator be installed so that the regulator vent faces downward to avoid the potential for water or other foreign matter entering the regulator and interfering with the proper operation of the regulator.

10 For application on combustible gas with a specific gravity greater than 1.0 (such as propane) it is recommended that the gas be vented outdoors where the gas will not collect in low areas and away from all open flames, arcing devices, etc.

CAUTION

Regulators are pressure control devices with numerous moving parts subject to wear. Regulator wear is dependent upon particular operating conditions. To assure continuous satisfactory operation, a periodic inspection schedule must be adhered to with the frequency of inspection determined by the severity of service and applicable laws and regulations.

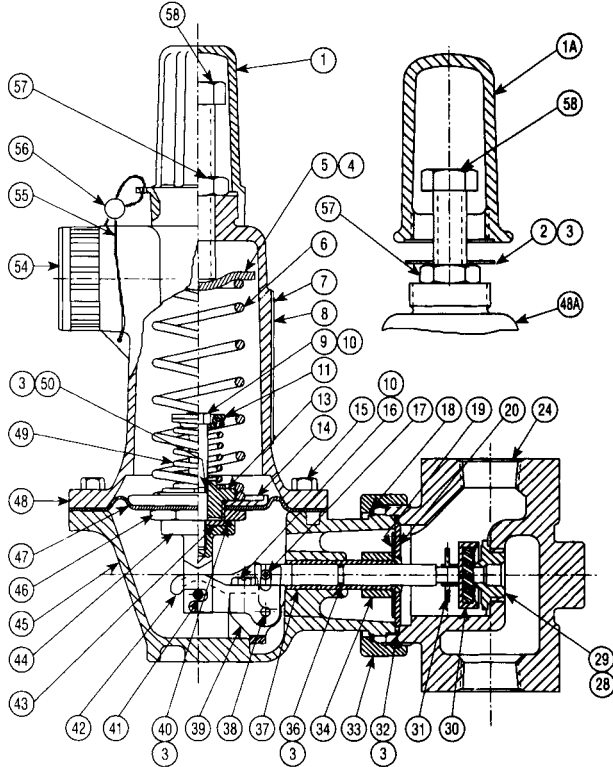

MODEL NO. 046-2

Service

- 1** Make sure regulator is entirely depressurized before disassembling.
- 2** In general, it is not necessary to disconnect the body (24) or (24A) from the piping. Leave in place in the line when servicing the regulator.
- 3** Carefully note location and position of each part during disassembly to make certain reassembly is correct. Replace all worn, damaged, or otherwise unsatisfactory parts.
- 4** To service the valve or orifice, first loosen coupling nut (33) and separate the diaphragm case assembly from the body. Remove and inspect the body to lower case seal (32). Replace if damaged. To remove the valve assembly (30), first remove hair pin (31). Orifice (29) unscrews from body using 1" hex socket wrench "thin wall" type. Use moderate amount of pipe dope on sealing surface (male threads) when replacing orifice.
- 5** During reassembly, make sure tetraseal (32) is correctly positioned. Tighten coupling nut (33) with a torque of 35 to 50 ft.-lbs.
- 6** To change spring (6), remove cover cap (1) or (1A), and turn adjustment screw (58) counterclockwise to remove spring load. Remove screws (15) or (15A), remove upper diaphragm case (48), (48A), or (48B) and spring ferrule (5). Make sure new spring is correctly nested on the diaphragm pan (14) or (14A) and install spring ferrule (5). Also, make sure diaphragm (47) or (47A) is not pinched.
- 7** To replace diaphragm, follow step 6 during disassembly and reassembly. Remove screw (9A) to disassemble diaphragm assembly and remove diaphragm (47) or (47A). On regulators with internal relief valve (all -2 models), remove IRV bolt (9), and IRV spring (49) slowly,

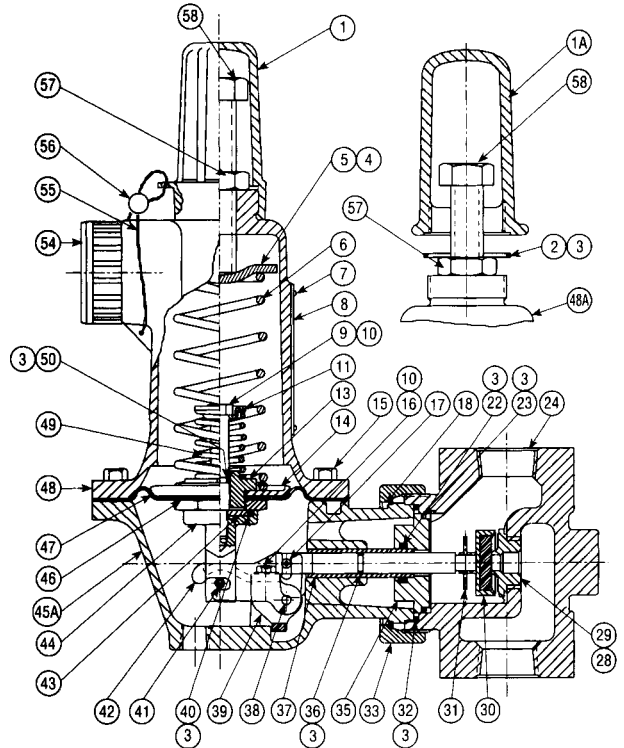

MODEL NO. 046-2M

as force is required to keep spring from expanding rapidly. Remove clamping nut (46) and replace diaphragm (47). Assemble the diaphragm (47) in reverse order. Inspect IRV "O" Rings (50) and (40), replace if necessary. Align roll pin (41) parallel and square to the diaphragm centerline. Make sure roll pin (41) or (41A) is correctly positioned as shown below. On reassembly, tighten screws (15) or (15A) evenly to a torque of 125 in.-lbs. The screws must be tight enough to prevent leakage but not so tight as to crush or damage the diaphragm. The diaphragm coupling roll pin (41) or (41A) must be assembled parallel and square to the diaphragm centerline to prevent binding of the coupling (44) or (44A) and lever (42). Also, the diaphragm (47) or (47A) must not be twisted or pinched.

- 8** Upon completing servicing, make sure the regulator is free of leaks.

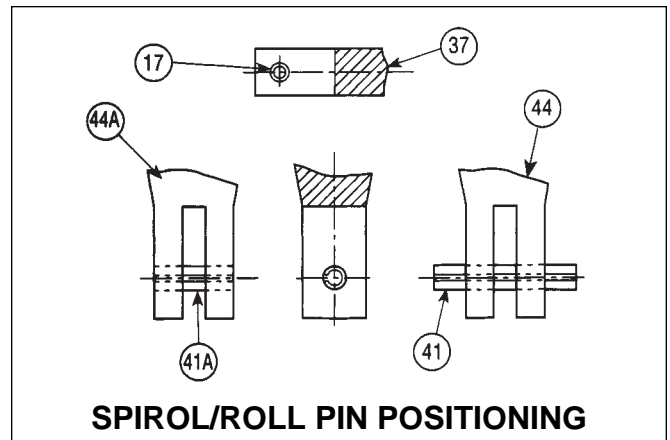

SPIROL/ROLL PIN POSITIONING

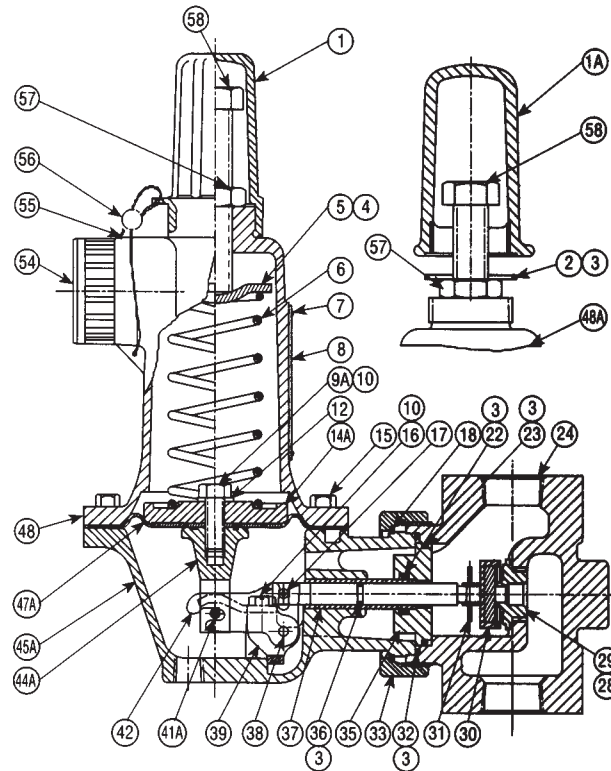

MODEL NO. 046-M

046 Parts List

The following are the parts for the 046 regulators. Those parts generally required in maintenance and servicing are highlighted.

ITEM NO	PART NO.	DESCRIPTION	ITEM NO	PART NO.	DESCRIPTION
1	046-00-005-00	Plastic cover cap	21	141-62-045-00	Boost tube
1a	046-00-005-01	Cast iron cover cap	22	934010	O-ring, buna-n
2	950805	Tetraseal, buna-n		902987	O-ring, viton
	950806	Tetraseal (or o-ring), viton	23	908771	O-ring, buna-n
3	1191074	O-ring lube		950746	O-ring, viton
4	1191073	Aero-lubriplate	24	046-00-001-06	Body, 3/4" conn.
5	141-62-009-00	Spring ferrule		046-00-001-04	Body, 1" conn.
6	See chart	Spring		046-00-001-05	Body, 1-1/4" conn.
7	914760	#0 x 1/8 lg. drive screw	24a	046-00-001-09	Body, 3/4" conn. w/inlet tap (1/4 NPT)
8	046-00-086-00	Nameplate		046-00-001-10	Body, 1" conn. w/inlet tap (1/4 NPT)
	046-00-086-01	Nameplate (taipei city)		046-00-001-11	Body, 1-1/4" conn. w/inlet tap (1/4 NPT)
9	046-00-153-00	IRV guide bolt	25	903989	Elbow 3/8 x 1/4 NPT
9a	910029	5/16-18 x 7/8 lg. hex head screw	26	903973	Conn. 3/8 tube x 1/4 NPT
10	906114	Loctite 242	27	51125	Tube 3/8 o.d. x .035 wall
11	046-00-009-00	Spring holder	28	905115	Loctite 222 mild
12	904983	Stat-o-seal (high temp only)	29	046-00-023-02	1/8 s.s. valve orifice
13	046-00-074-00	Guide bushing		046-00-023-03	3/16 s.s. valve orifice
14	046-00-022-01	Diaphragm pan (IRV)		046-00-023-04	1/4 s.s. valve orifice
14a	046-00-022-00	Diaphragm pan		046-00-023-05	5/16 s.s. valve orifice
15	951136	5/16-18 x 3/4 hex hd cap screw		046-00-023-06	3/8 s.s. valve orifice
15a	907558	1/4-20 x 5/8 lg. hex hd cap screw		046-00-023-07	1/2 s.s. valve orifice
16	903164	1/4-20 x 3/4 lg. hex hd thd forming screw		046-00-023-22	1/8 brass valve orifice
16a	903314	#10-24 x 1/2 lg. bind hd mach screw		046-00-023-23	3/16 brass valve orifice
17	950381	Spirol pin 5/32 x 5/16 lg.		046-00-023-24	1/4 brass valve orifice
18	141-62-130-00	Retaining ring		046-00-023-25	5/16 brass valve orifice
19	141-62-035-00	Stabilizer disc		046-00-023-26	3/8 brass valve orifice
20	141-62-034-00	Stabilizer		046-00-023-27	1/2 brass valve orifice
			30	141-62-511-03	Valve ass'y, buna-n
				141-62-511-03	Valve ass'y, poly-u tan
				141-62-511-04	Valve ass'y, viton

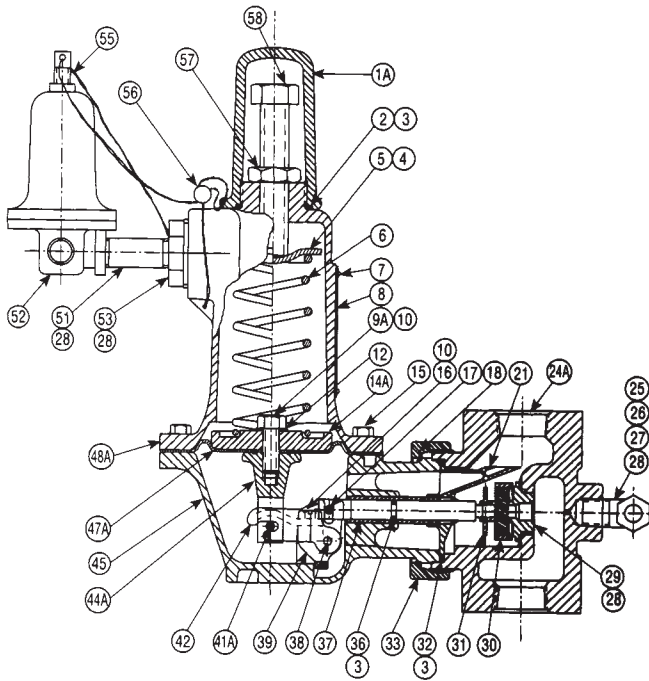

MODEL NO. 046-PL

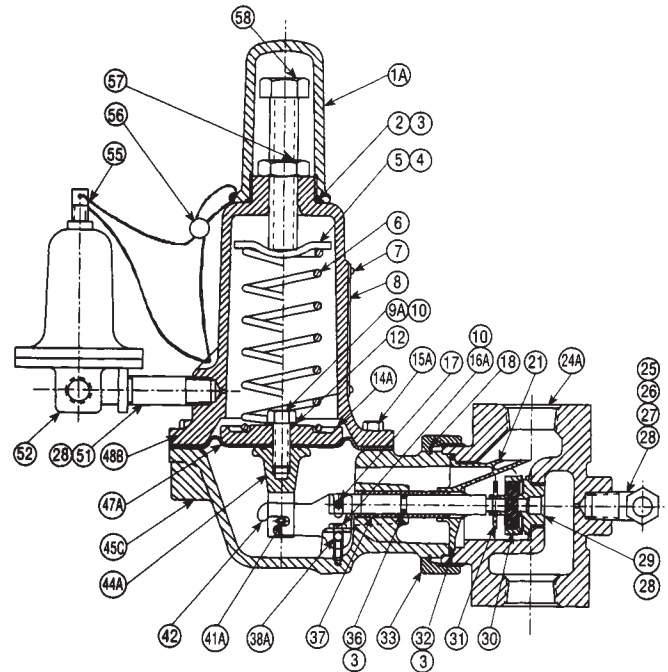

MODEL NO. 046-CPL

046 Parts List

The following are the parts for the 046 regulators. Those parts generally required in maintenance and servicing are highlighted.

ITEM NO	PART NO.	DESCRIPTION
31	141-62-118-00	Hair Pin Cotter
32	902497	Tetraseal, buna-n
	907718	Tetraseal (or o-ring), viton
33	143-62-102-00	Coupling nut
34	141-62-036-00	Stabilizer hub
35	046-00-038-00	Monitor throat block
36	934005	O-ring, buna-n
	904839	O-ring, viton
37	046-00-016-00	Valve stem, brass
	046-00-016-01	Valve stem, stainless steel (s.s.)
38	950728	Fulcrum dowel pin 3/16 x 3/4 lg. (s.s.)
38a	141-62-033-00	Fulcrum pin
39	046-00-029-00	Pivot bracket
40	904824	O-ring, buna-n
41	901695	Roll pin, 3/16 x 1-1/4 lg.
41a	901697	Roll pin 3/16 x 5/8 lg.
42	046-00-030-00	Lever
43	046-00-154-00	IRV coupling disc
44	046-00-028-01	Diaphragm coupling (IRV)
44a	046-00-028-00	Diaphragm coupling
45	046-00-602-09	Lower case (s.s. bushing ass'y)
	046-00-602-08	Lower case (brass bushing ass'y)
45a	046-00-602-11	Monitor lower case (s.s. bushing ass'y)
	046-00-602-10	Monitor lower case (brass bushing ass'y)
45c	046-00-602-07	CI Lower case (s.s. bushing ass'y)
	046-00-602-06	CI Lower case (brass bushing ass'y)

ITEM NO	PART NO.	DESCRIPTION
46	046-00-155-00	Clamping nut
47	046-00-150-01	IRV diaphragm, buna-n
47a	046-00-150-00	Diaphragm, buna-n
	046-00-150-02	Diaphragm, viton
48	046-00-003-03	Upper case (alum) cover
48a	046-00-003-04	Upper case (alum w/thd's) cover
48b	046-00-003-01	Upper case (cast iron w/thd's) cover
49	080-02-021-01	Spring dark blue (IRV)
50	934003	O-ring, buna-n
51	924059	Nipple 1/4 x 2"
52	1191495	Pilot 67R 3-20 psi
	1191496	Pilot 67R 5-35 psi
	1191497	Pilot 67R 30-60 psi
	1191498	Pilot 67R 35-100 psi
	1191509	Pilot 67RS 3-20 psi IRV
	1191510	Pilot 67RS 5-35 psi IRV
	1191511	Pilot 67RS 30-60 psi IRV
	1191512	Pilot 67RS 35-100 psi IRV
53	904397	Hex bushing 1" npt to 1/4 NPT
54	046-00-527-00	Vent assembly 1" NPT
54a	137-02-505-03	Vent cap assembly
55	001-63-057-50	Seal wire 12" lg.
56	001-60-157-00	Seal
57	921006	9/16-12unc hex steel jam nut
58	950655	9/16-12unc x 3" lg. hex hd stl cap scr
Not Shown	141-62-086-04	Customer badge

Over-Pressurization Protection

Protection must be provided for the downstream piping system and the regulator's low pressure chambers to assure against the potential over-pressurization due to a regulator malfunction or a failure of the regulator to lock-up. The allowable over-pressurization is the lowest of the maximum pressures permitted by federal codes, state codes, Invensys Bulletin RDS-1498, or other applicable standards. The method of providing over-pressure protection could be a relief valve, a monitor regulator, a shut off device, or any similar device.

Internal Relief Valve (IRV) Capacity

Internal Relief Valves, like all relief valves, must be carefully checked for adequate capacity. IRV's only have full capacity relief capability when the inlet pressure to the regulator is low enough and the regulator orifice is small enough. If either one, or both, are too large, the IRV will not have full capacity relief capability and will not be able to prevent the outlet pressure from exceeding the maximum allowable limit.

Capacity for the full open 046 IRV can be calculated with the formula

$$Q = \frac{K P_o}{2} \text{ for 0.6 specific gravity gas}$$

where

- K = 600 (the IRV constant)
- P_o = absolute outlet pressure (psia)

Field regulators with internal relief valves can be obtained by specifying Models 046-2 or 046-2M. The 046-2M is a limited capacity IRV unit due to flow through the control line.

Spring Ranges

046, 046-M, 046-C & 046-CM Models

Outlet Pressures	Spring Color	Part Number
3 to 10 psig	Yellow	046-00-021-00
8 to 20 psig	Aluminum	046-00-021-01
15 to 52 psig	White	046-00-021-02
50 to 125 psig	Tan	046-00-021-03
100 to 200 psig	Gray	046-00-021-04
10 to 95 psig	Dark Green ¹	046-00-021-05

046-2, 046-2M Models

Outlet Pressures	Spring Color	Part Number
3 to 10 psig	Yellow	046-00-021-00
8 to 20 psig	Aluminum	046-00-021-01
15 to 52 psig	White	046-00-021-02
50 to 125 psig	Tan	046-00-021-03
10 to 95 psig	Dark Green ¹	046-00-021-05

1. General Purpose Spring.

Spring Ranges and Combinations

046-PL & 046-CPL

For This Outlet Pressure Range	Use These Springs	
	046 Regulator	Loading Regulator
5 to 15 psi	Yellow 3 psig	2 to 20 psig
15 to 25 psi	Yellow 10 psig	2 to 20 psig
20 to 40 psi	Yellow 10 psig	5 to 35 psig
30 to 50 psi	Alum. 20 psig	5 to 35 psig
50 to 75 psi	Alum. 20 psig	30 to 60 psig
60 to 100 psi	Alum. 20 psig	35 to 100 psig

Full Open Capacity

Use the following formulas for calculating the full open capacity of 046 regulators. Do not use full open capacity when sizing one of these regulators for an application. Instead, use the capacity tables in Bulletin R-1312.

$$1. Q = K \sqrt{P_o (P_i - P_o)}$$

$$2. Q = \frac{K P_i}{2}$$

Q = maximum capacity of the regulator (in SCFH of 0.6 specific gravity natural gas).

K = the "K" factor, the regulator constant (from table below).

P_i = absolute inlet pressure (psia).

P_o = absolute outlet pressure (psia).

Use formula 1. when $\frac{P_i}{P_o}$ is less than 1.894.

Use formula 2. when $\frac{P_i}{P_o}$ is greater than 1.894.

Orifice	1/8"	3/16"	1/4"	5/16"	3/8"	1/2"
"K" Factor	33	74	132	206	292	520

When sizing relief valves for use with 046 regulators, use full open capacity as calculated with the above formulas. Do not use values from the capacity tables in Bulletin R-1312.

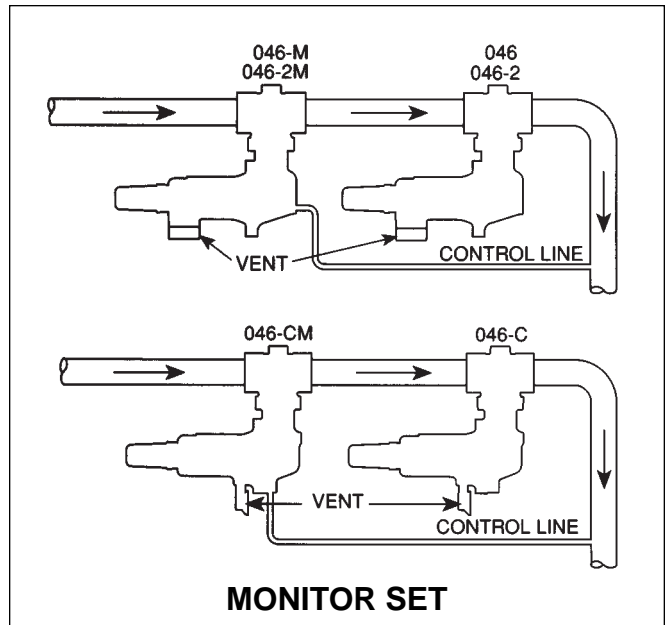

Monitoring

The 046 regulator makes an excellent monitor; a standby regulator installed in series which assumes control if a failure in the operating regulator permits the outlet pressure to exceed the set-point. It can be located in either the upstream or the downstream position.

When an 046 is used to monitor a regulator with an identical inner valve (another 046), the total maximum capacity through both regulators can be figured at 70% of the capacity of one of them alone. This applies with the monitor located either up or downstream.

Maximum Emergency Pressure

The maximum pressure the regulator inlet may be subjected to, under abnormal conditions without causing damage to the regulator is:

046, 046-2, 046-C, 046-M, 046-2M,
046-PL and 046-CPL.....Max. Inlet Pressure +100 psi

The maximum pressure the regulator outlet may be subjected to without causing damage to the internal parts of the regulator is:

For set-points of 3 to 200 psiset point +100 psi

Set-point is defined as the outlet pressure a regulator is adjusted to deliver.

If any of the above pressure limits are exceeded, the regulator must be taken out of service and inspected. Damaged or otherwise unsatisfactory parts must be replaced or repaired.

The maximum pressure that can be safely contained by the diaphragm case is:

046, 046-2, 046-C, 046-M, 046-2M 400 psi
046-PL & 046-CPL..... 250 psi

Safely contained means no leakage as well as no bursting.

Temperature Limits

The 046 Regulators can be used for flowing temperatures from -20°F. to 150°F.

Other Gases

The 046 Regulators are mainly used for natural gas service; however, these regulators will perform equally as well on other gases. When using the 046 Regulators on other gases, the regulator capacities must be adjusted using the following correction factors.

Type of Gas	Correction Factor
Air (specific gravity 1.0)	0.77
Propane (specific gravity 1.53)	0.63
1350 BTU Propane-Air Mixture (specific gravity 1.20)	0.71
Nitrogen (specific gravity 0.97)	0.79
Dry CO ₂ (specific gravity 1.52)	0.63

For other noncorrosive gases use the following formula:

$$\text{Correction Factor} = \sqrt{\frac{0.60}{\text{Specific gravity of the Gas}}}$$

For use with gases not listed above, please contact your Sensus Representative or Industrial Distributor for recommendations.

Buried Service

The 046 Regulators **are not** recommended for buried service.

Dimensions

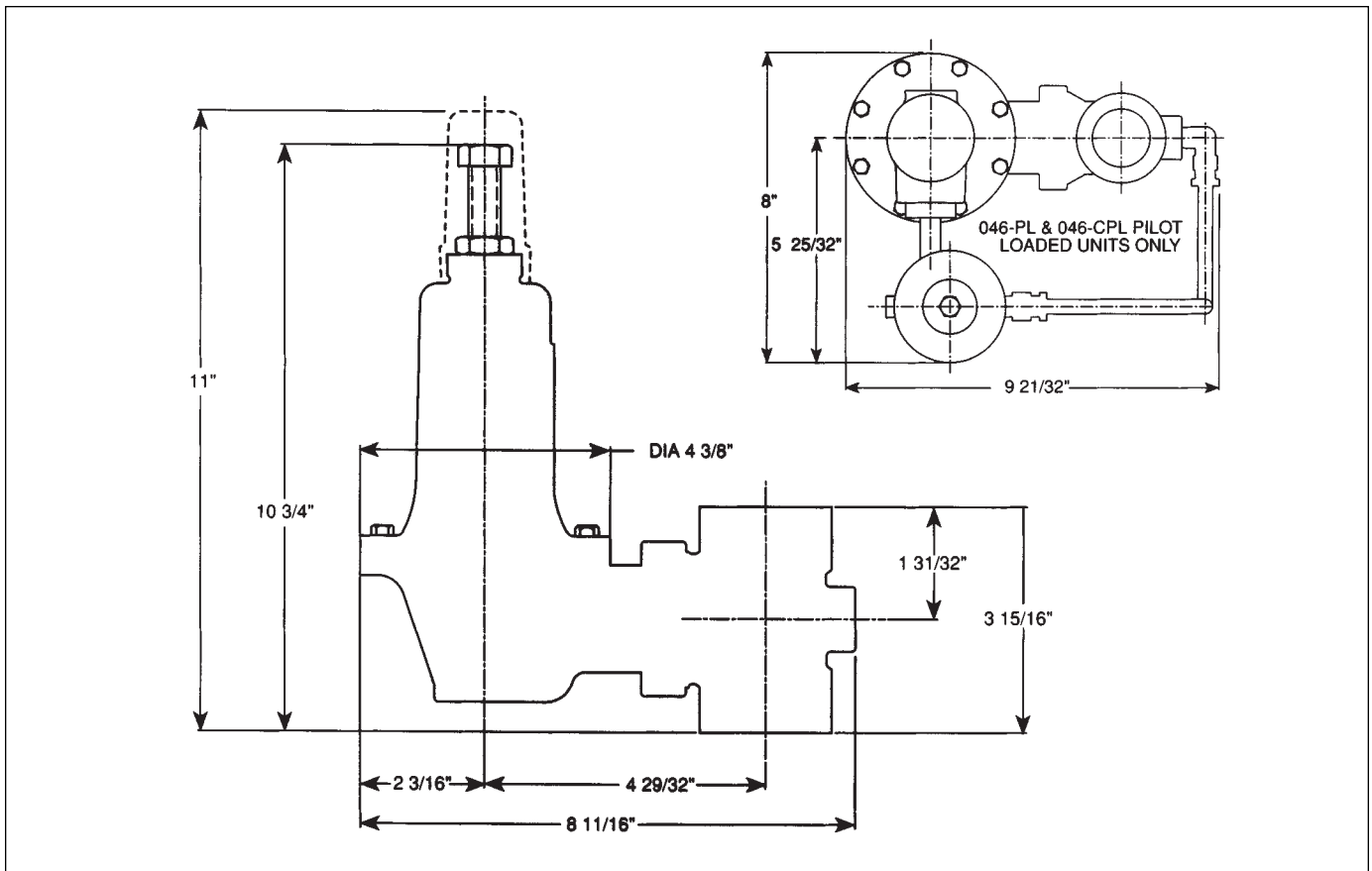



805 Liberty Boulevard
DuBois, PA 15801
814-375-8875
Fax 814-375-8460

Authorized Distributor

Limited Warranty

Seller warrants the Goods to be free from defects in materials manufactured by Seller and in Seller's workmanship for a period of one (1) year after tender of delivery (the "Warranty Period"). THIS LIMITED WARRANTY (a) IS IN LIEU OF, AND SELLER DISCLAIMS AND EXCLUDES ALL OTHER WARRANTIES, STATUTORY, EXPRESS OR IMPLIED, INCLUDING, WITH LIMITATION, ANY WARRANTY OF MERCHANTABILITY OR FITNESS FOR A PARTICULAR PURPOSE, OR OF CONFORMITY TO MODELS OR SAMPLES; (b) does not apply to any Goods which have been (i) repaired, altered or improperly installed; (ii) subjected to improper use or storage, (iii) used or incorporated with other materials or equipment, after buyer or anyone using the Goods has, or reasonably should have, knowledge of any defect or nonconformance of the Goods; or (iv) manufactured, fabricated or assembled by anyone other than Seller, (c) shall not be effective unless buyer notifies Seller in writing of any purported defect or nonconformance with (thirty days) after Buyer discovers or should have reasonably discovered such purported defect or nonconformance; and (d) shall only extend to Buyer and not to any subsequent buyers or users of the Goods. Buyer shall provide Seller access to the Goods as to which Buyer claims a purported defect or nonconformance, upon request by Seller, buyer shall, at its own risk and expense, promptly return the Goods in question to Seller's Plant.