

# SR II-EB II<sup>®</sup> Meters

## Displacement Type Magnetic Drive Cold Water Meters

### 5/8" (DN 15mm), 3/4" (DN 20mm) and 1" (DN 25mm) Sizes

#### DESCRIPTION

**Applications:** Measurement of cold water where flow is in one direction only; in residential, commercial and industrial services.

**Conformance To Standards:** Sensus SR II-EB II Water Meters meet the requirements of NSF Standard 61 and comply with ANSI/AWWA Standard C700-latest revision. Each meter is tested to insure compliance with AWWA standards.

**Construction:** Sensus SR II-EB II Water Meters consist of three basic components: maincase; measuring chamber; and sealed register. Maincases are made of EnviroBrass II™ C89520 alloy with externally-threaded spuds. Registers are housed in a bonnet of synthetic polymer. Measuring chambers are of Rocksyn®, a corrosion-resistant, tailored thermoplastic material formulated for long-term performance and especially suitable for aggressive water conditions. Maincase bottom plates are available in Enviro-Brass II™ or, if frost protection is desired, in cast iron or synthetic polymer<sup>1</sup>.

**Sealed Register:** Hermetically sealed; proven magnetic drive design eliminates dirt and moisture contamination, tampering and lens fogging problems. Standard register includes a straight-reading, odometer-type totalization display; a 360° test circle with center sweep hand; and a low flow (leak) detector. Gears are selflubricating, molded plastic for long life and minimum friction.

No change gears are required for accuracy calibration. Encodertype remote reading systems are available for all SR II-EB II Water Meters. (See other side of sheet for additional information.)

**Tamperproof Features:** A unique locking system prevents customer removal of the register to obtain free water. A special tool, available only to water utilities, is required to remove the register bonnet.

**Magnetic Drive:** The SR II-EB II features a hydrodynamically cushioned design that eliminates premature wear of components. The meter utilizes a patented positive, reliable drive coupling. The high-strength magnets used will eliminate "drive slip" in normal use and also provide adequate strength to drive remote register units.

**Operation:** Water flows through the meter's strainer and into the measuring chamber where it drives the piston. The hydrodynamically balanced piston oscillates around a central hub, guided by the division plate.

A drive magnet transmits the motion of the piston to a driven magnet located within the hermetically sealed register. The driven magnet is connected to the register gear train. It reduces the piston oscillations into volume totalization units displayed on the register dial face.



5/8" SR II-EB AMR (pictured) 3/4" and 1" available



5/8" AMR System Dials Shown

**Maintenance:** Sensus SR II-EB II Water Meters are engineered to provide long-term value and virtually maintenance-free operation. Simplicity of design and precise machining of components allows interchangeability of parts of like-size meters, reduced parts inventory requirements, and ease of maintenance. The register can be removed without relieving the water pressure or removing the maincase from the installation.

**Connections:** Tailpieces/Unions for installing the meters on a variety of pipe types and sizes are available.

**AMR / AMI Systems:** Meters and encoders are compatible with current Sensus AMR/AMI systems.

**Guarantee:** Sensus SR II Water Meters are backed by "The Sensus Guarantee." Ask your Sensus representative for details or see Bulletin G-500.

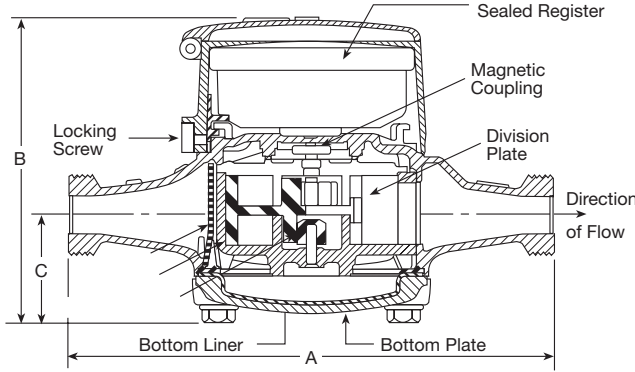

**DIMENSIONS AND NET WEIGHTS**

Meter Size	A	B	C	Width	Net Weight <sup>1</sup>
5/8" (DN 15mm)	7-1/2" (190mm)	5.0" (127mm)	1-3/4" (44mm)	3-7/8" (98mm)	4.3 lb. (1.97 kg)
5/8" x 3/4" (DN 15mm x 33mm)	7-1/2" (190mm)	5.0" (127mm)	1-3/4" (44mm)	3-7/8" (98mm)	4.4 lb. (2.00 kg)
3/4" (DN 20mm)	9" (229mm)	5-1/2" (140mm)	2-3/16" (56mm)	4-1/2" (114mm)	6.4 lb. (2.90 kg)
3/4" x 1" (DN 20mm x 42mm)	9" (229mm)	5-1/2" (140mm)	2-3/16" (56mm)	4-1/2" (114mm)	6.6 lb. (2.99 kg)
3/4" short (DN 20mm)	7-1/2" (190mm)	5-1/2" (140mm)	2-3/16" (56mm)	4-1/2" (114mm)	6.2 lb. (2.81 kg)
1" (DN 25mm)	10-3/4" (273mm)	6-9/16" (167mm)	2-7/16" (62mm)	6-1/2" (165mm)	11.9 lb. (5.4 kg)

<sup>1</sup> With Rocksyn® measuring chamber.

**SPECIFICATIONS**

<b>SERVICE</b>	Measurement of cold water with flow in one direction only.
<b>NORMAL OPERATING FLOW RANGE <sup>1</sup></b>	5/8" (DN 15mm) size: 1 to 20 gal/min. (0.25 to 4.5 m <sup>3</sup> /h) 3/4" (DN 20mm) size: 2 to 30 gal/min. (0.45 to 7.0 m <sup>3</sup> /h) 1" (DN 25mm) size: 3 to 50 gal/min. (0.7 to 11.0 m <sup>3</sup> /h)
<b>ACCURACY</b>	100% ± 1.5% of actual thruput
<b>LOW FLOW REGISTRATION</b>	5/8" size: 95% at 1/4 gal/min. (0.06 m <sup>3</sup> /h) 3/4" size: 95% at 1/2 gal/min. (0.10 m <sup>3</sup> /h) 1" size: 95% at 3/4 gal/min (0.15 m <sup>3</sup> /h)
<b>MAXIMUM PRESSURE LOSS</b>	5/8" size: 7.0 psi at 20 gal/min. (0.5 bar at 4.5 m <sup>3</sup> /h) 3/4" size: 9.0 psi at 30 gal/min. (0.6 bar at 7.0 m <sup>3</sup> /h) 1" size: 7.3 psi at 50 gal/min. (0.5 bar at 11.0 m <sup>3</sup> /h)
<b>MAXIMUM OPERATING PRESSURE</b>	150 psi (10.0 bar)
<b>MEASURING ELEMENT</b>	Oscillating piston
<b>REGISTER <sup>3</sup></b>	Straight reading, hermetically sealed, magnetic drive. Remote reading unit optional.
<b>STANDARD METER REGISTRATION <sup>3</sup></b>	10 gallons, 1 cubic foot, or 0.01 m <sup>3</sup> or 0.1 m <sup>3</sup> /sweep hand revolution. 10,000,000 gallons, 1,000,000 cubic feet or 100,000 m <sup>3</sup> capacity. 6 odometer wheels.

<b>METER CONNECTIONS <sup>3</sup></b>	5/8" (DN 15mm) size: 3/4" (26.44mm) threads 5/8" x 3/4" (DN 15mm x 33mm) size: 1" (33.25) threads 3/4" (DN 20mm) size: 1" (33.25 threads) 3/4" x 1" (DN 20mm x 42mm) size: 1-1/4" (41.91mm) threads 1" (DN 25mm) size: 1-1/4" (41.91mm) threads (All threads are straight pipe, external type, conforming to ANSI B1.20.1 or ISO R228, if specified.)
<b>MATERIALS</b>	Maincase—EnviroBrass II™ C8952 alloy Register box—Synthetic polymer Measuring chamber—Rocksyn® Bottom plate—EnviroBrass II™ Magnets—Plasticized material Casing bolts—Stainless steel Strainer—Synthetic polymer

<sup>1</sup> Maximum rates listed are for intermittent flow only. Maximum continuous flow rates as specified by AWWA are: 5/8" (DN 15mm)—10 gal/min (2.3 m<sup>3</sup>/h), 3/4" (DN 20mm)—15 gal/min (3.4 m<sup>3</sup>/h) 1" (DN 25mm)—25 gal/min (5.7 m<sup>3</sup>/h)  
<sup>2</sup> Unless otherwise noted, 5/8" size and 5/8" x 3/4" characteristics are identical. (5/8" x 3/4" designates 5/8" with 3/4" connection thread.) Also unless otherwise noted 3/4" size and 3/4" x 1" size characteristics are identical. (3/4" x 1" designates 3/4" with 1" connection thread.)  
<sup>3</sup> See AMR Systems Register datasheet AMR-275 for details specifications.



P.O. Box 487 | 450 North Gallatin Avenue  
 Uniontown, PA 15401 USA  
 T: 1-800-638-3748  
 F: 1-800-888-2403  
 www.sensus.com/water  
 h2oinfo@sensus.com

**AUTHORIZED SENSUS DISTRIBUTOR**