Models 461-S, 461-8S and 461-12S Regulators

R-1330
Rev. 8



SENSUS

461-S, 461-8S and 461-12S Regulators



The Sensus Models 461-S, 461-8S and 461-12S are balanced valve, spring type regulators designed for distribution and industrial applications where a single seat regulator is too small and the usual 2" balanced valve regulators are too large. They are made in 2" pipe sizes only and are used for:

Inlet Pressures to 175 psi
Outlet Pressures of 0 to 10 psi

Contoured body passages for reducing turbulence and large exit areas give them a broad capacity capability thus making them applicable to a wide variety of load handling requirements.

Their outstanding control characteristics are illustrated by the curves on Page 4. Capacities are provided on Page 7.

The 461-S and 461-12S are unusually dependable regulators. Their design is simple, the construction is sturdy. Servicing and adjustment are easy, response is fast. The overall operation is stable and sensitive, and they provide exceptionally precise regulation.

The 461-S 461-8S and 461-12S are excellent regulators for general usage. They also make an excellent choice for such special applications as snap action on-off loads and monitoring service.

| Maximum Inlet Pressure | Diaphragm Size I.D. | Diaphragm Case Material | Maximum Inlet Pressure* |
|------------------------|---------------------|-------------------------|-------------------------|
| | 12" | Cast Iron | 100 psi |
| | 8½" | Cast Iron | 175 psi |
| | 12" | Aluminum | 100 psi |
| | 8" | Aluminum | 175 psi |

*The regulator should not be used for pressures exceeding the recommended maximum inlet.

| Maximum Pressure Differential and Maximum Inlet Pressure for Various Soft-Seated Valve Materials* | Valve Material | Maximum Pressure Differential | Maximum Inlet Pressure |
|---|-----------------------------------|-------------------------------|------------------------|
| | Buna-N (black, 50 to 55 duro) | 250 psi | 575 psig |
| | Polyurethane (red, 65 to 75 duro) | 400 psi | 720 psig |
| | Polyurethane (tan, 85 to 95 duro) | 600 psi | 1200 psig |

*The differential and inlet pressures given are only to be used as general guidelines. In all cases, pressures must always remain within the ranges specified in Sensus literature. For any given regulator, do not exceed the specified maximum pressures.

The maximum temperature for the above materials is 150°F.

Vitron valve material has a maximum temperature rating of 300°F and a maximum pressure differential of 250 psi.

| Body Pressure Ratings | Regulator Body Type | Maximum Working Pressure of Body* |
|-----------------------|-------------------------|-----------------------------------|
| | Screwed End | 250 psi |
| | Flanged ANSI 125 lb. FF | 175 psi |
| | Flanged ANSI 250 lb. RF | 575 psi |
| | Flanged ANSI 300 lb. RF | 720 psi |

*This only applies to the body. The regulator should not be used for inlet pressures that exceed the maximums specified in the Maximum Inlet Pressure table above.

Spring Ranges

| | Outlet Pressure | | Nominal Diaphragm Size (I.D.) and Case Material | Spring Color † |
|-----------|-----------------|---------------|---|----------------|
| | Minimum | Maximum | | |
| *2" w.c. | 10" w.c. | 12" Cast Iron | Aluminum | |
| 4" w.c. | 16" w.c. | 12" Cast Iron | Green | |
| 7" w.c. | 29" w.c. | 12" Cast Iron | Yellow | |
| 0.5 psi | 1.75 psi | 12" Cast Iron | Gray | |
| 1 psi | 3.5 psi | 12" Cast Iron | Blue | |
| 3.5" w.c. | 6.5" w.c. | 12" Aluminum | Red | |
| 5" w.c. | 8.5" w.c. | 12" Aluminum | Blue | |
| 6" w.c. | 14" w.c. | 12" Aluminum | Green | |
| 12" w.c. | 28" w.c. | 12" Aluminum | Orange | |
| 1 psi | 2 psi | 12" Aluminum | Black | |
| 1.5 psi | 3 psi | 12" Aluminum | Cadmium | |
| 3 psi | 6 psi | 8½" Cast Iron | Blue | |
| 5 psi | 10 psi | 8½" Cast Iron | Red | |
| 1 psi | 2 psi | 8" Aluminum | Orange | |
| 2 psi | 4.25 psi | 8" Aluminum | Black | |
| 3 psi | 6.5 psi | 8" Aluminum | Cadmium | |
| 6 psi | 10 psi | 8" Aluminum | Cadmium (outer) White (inner) | |

For outlet pressures above 3 psi refer also to:

Model 461-57S - a direct operated spring regulator for 100 psi maximum outlet (Bulletin R1331).

Model 1100 - a pilot operated regulator for 150 psi maximum outlet (Bulletin R1341).

*For pressures below 2" w.c. install regulator in inverted position.

†Springs are colored for identification. When shipped, the regulator is equipped with the lightest possible spring suitable for the maximum outlet pressure specified on order. If outlet conditions change, replace spring according to table for best operation.

Temperature Limits

The 461-S, 461-8S and 461-12S regulators may be used for flowing gas temperatures from -20° to 150°F.

Buried Service

The 461-S, 461-8S and 461-12S regulators are **not** recommended for buried service.

**461-S, 461-8S and 461-12S
Gas Pressure Regulators**

**Heavy Duty
Cast Iron
Diaphragm Case (shown)**

(Sizes 8½" and 12" I.D.)

**Lightweight Aluminum
Diaphragm Case**

(Sizes 8" and 12" I.D.)

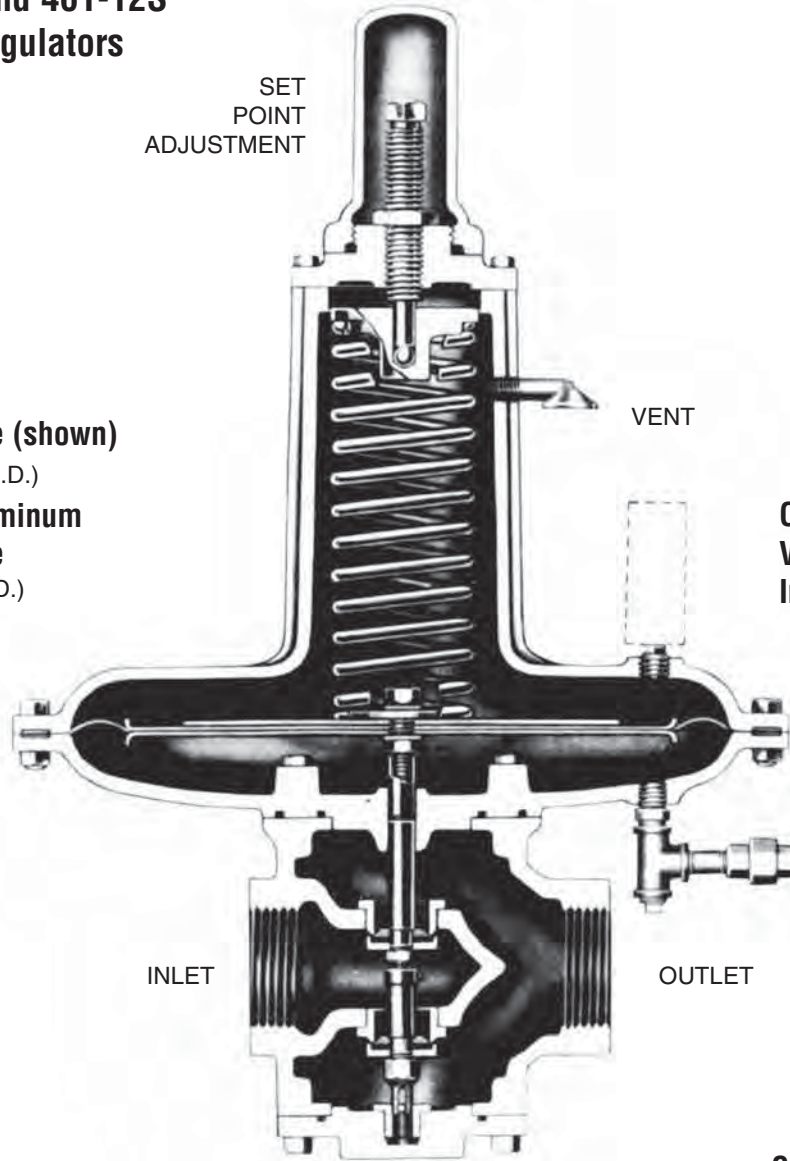

**Optional
Valve Travel
Indicator**

**Control Line
Connection**

(Differs on Aluminum case 461-8S and 461-12S. See bulletin RM-1330.)

**Balanced Valve
Full Size and
Reduced Sizes**

(See pages 7 and 8)

**Cast Iron,
Ductile Iron or
Cast Steel Body**

(See pages 10 and 11)

Construction Features

Regulator self contained-no exposed parts-top moisture sealed-safe for pits by extending vent line.

Flow contoured body-large gas exit area reduces turbulence, increased capacity.

Side inspection plates-O-ring sealed-for visual valve inspection or adjustment.

Balanced valve-permits higher inlet pressures-eliminates variation effect-gives greater capacity.

Soft seat valves-tight lock-up at zero flow. Molded discs resist blow out. Adjustable valve spacing. Renewable orifices-two interchangeable sizes.

Springs color coded-self-aligning adjustment-easily changed through gasketed top opening.

Typical Performance Curves

Performance

These performance curves are typical for the Model 461-S.

The outlet pressure for each chart was set under the stated conditions and was not further adjusted during changes in inlet pressure or flow. Settings in general were made at an inlet of 5 psi. From set point to lock-up at zero flow requires a pressure increase of not more than 3" w.c.

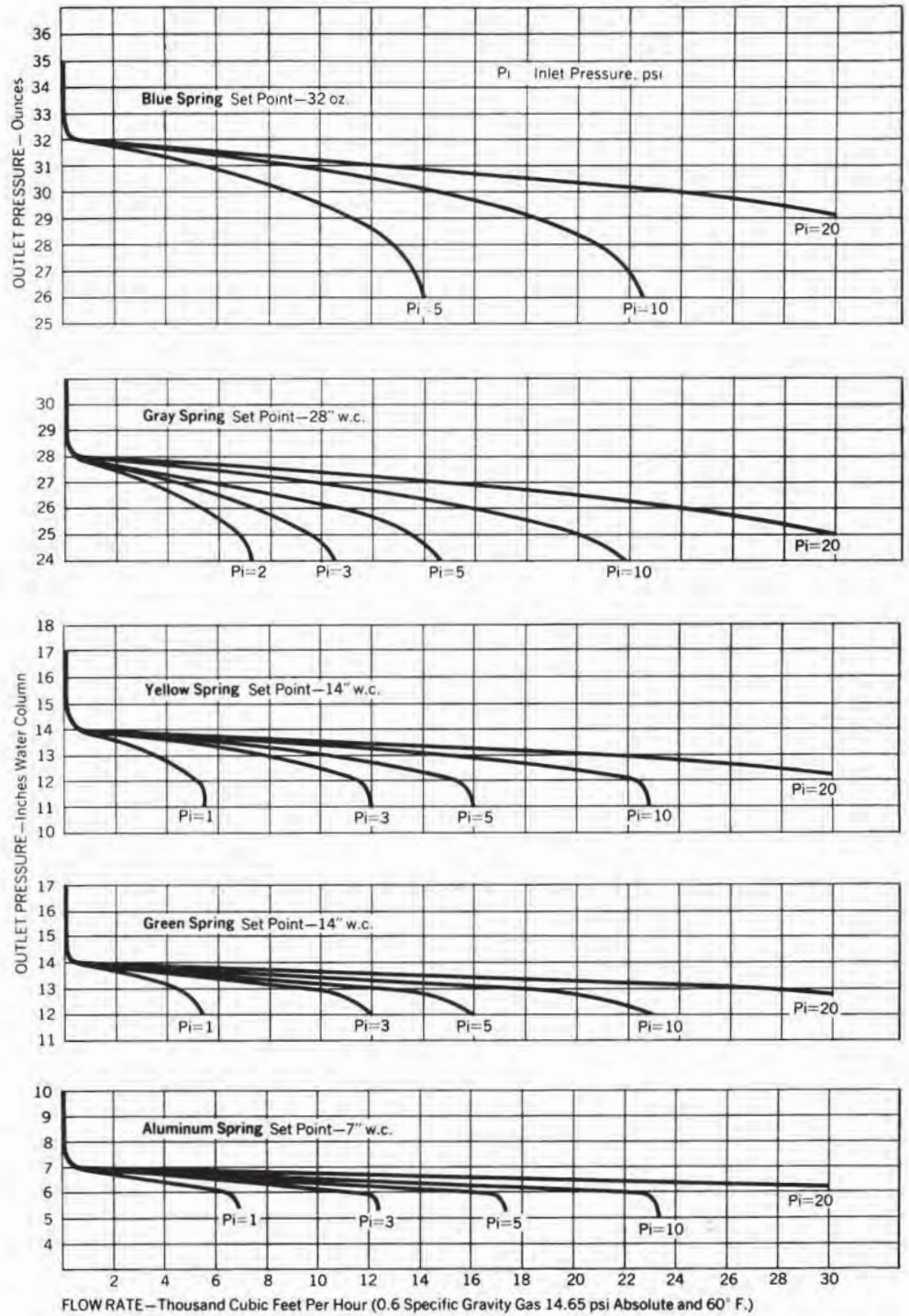



Capacity in 1000SCFH of Natural Gas (0.6 Specific Gravity-14.65 psia-60°F)

| Inlet Pressure psi | Outlet Pressure psi | Double Seat Balanced | | Single Seat Balanced* | |
|--------------------|---------------------|----------------------|-------------|-----------------------|-------------|
| | | 1" Valve | 1/16" Valve | 1" Valve | 1/16" Valve |
| 1/4 | 4" w.c. | 2.5 | 1.25 | — | — |
| | 7" w.c. | 3.8 | 1.9 | — | — |
| 1/2 | 4" w.c. | 4.5 | 2.27 | — | — |
| | 7" w.c. | 3.8 | 1.9 | — | — |
| 1 | 4" w.c. | 7.0 | 3.5 | — | — |
| | 7" w.c. | 6.6 | 3.3 | — | — |
| | 1/2 psi | 5.4 | 2.73 | — | — |
| 2 | 4" w.c. | 10.4 | 5.2 | — | — |
| | 7" w.c. | 10.0 | 5.0 | — | — |
| | 1/2 psi | 9.4 | 4.7 | — | — |
| | 1 psi | 7.8 | 3.9 | — | — |
| 3 | 4" w.c. | 12.8 | 6.4 | — | — |
| | 7" w.c. | 12.6 | 6.3 | — | — |
| | 1/2 psi | 12.2 | 6.1 | — | — |
| | 1 psi | 11.0 | 5.5 | 7.1 | 3.5 |
| | 2 psi | 8.0 | 4.0 | 5.2 | 2.6 |
| 4 | 4" w.c. | 15.0 | 7.5 | — | — |
| | 7" w.c. | 14.8 | 7.4 | — | — |
| | 1/2 psi | 14.4 | 7.2 | — | — |
| | 1 psi | 13.6 | 6.8 | 8.8 | 4.4 |
| | 2 psi | 11.4 | 5.7 | 7.4 | 3.7 |
| 5 | 3 psi | 8.4 | 4.2 | 5.4 | 2.7 |
| | 4" w.c. | 16.8 | 8.4 | — | — |
| | 7" w.c. | 16.6 | 8.3 | — | — |
| | 1/2 psi | 16.4 | 8.2 | — | — |
| | 1 psi | 15.6 | 7.8 | 10.1 | 5.0 |
| | 2 psi | 14.0 | 7.0 | 9.1 | 4.5 |
| 6 | 3 psi | 11.8 | 5.9 | 7.6 | 3.8 |
| | 4 psi | 8.6 | 4.3 | 5.6 | 2.8 |
| | 7" w.c. | 18.2 | 9.1 | — | — |
| | 1/2 psi | 18.0 | 9.0 | — | — |
| | 1 psi | 17.6 | 8.8 | 11.4 | 5.7 |
| | 2 psi | 16.2 | 8.1 | 10.5 | 5.2 |
| 8 | 3 psi | 14.4 | 7.2 | 9.3 | 4.3 |
| | 4 psi | 12.2 | 6.1 | 7.9 | 3.9 |
| | 5 psi | 8.8 | 4.4 | 5.7 | 2.8 |
| | 7" w.c. | 21.2 | 10.6 | — | — |
| | 1/2 psi | 21.0 | 10.5 | — | — |
| | 1 psi | 20.8 | 10.4 | 13.5 | 6.7 |
| 10 | 2 psi | 19.8 | 9.9 | 12.8 | 6.4 |
| | 3 psi | 18.6 | 9.3 | 12.1 | 6.0 |
| | 4 psi | 17.2 | 8.6 | 11.1 | 5.6 |
| | 5 psi | 15.2 | 7.6 | 9.8 | 4.9 |
| | 6 psi | 12.8 | 6.4 | 8.3 | 4.1 |
| | 7" w.c. | 23.8 | 11.9 | — | — |
| | 1/2 psi | 23.6 | 11.8 | — | — |
| | 1 psi | 23.4 | 11.7 | 15.2 | 7.6 |
| 10 | 2 psi | 23.0 | 11.5 | 14.9 | 7.4 |
| | 3 psi | 22.2 | 11.1 | 14.4 | 7.2 |
| | 4 psi | 21.0 | 10.5 | 13.6 | 6.8 |
| | 6 psi | 18.0 | 9.0 | 11.7 | 5.8 |
| 8 psi | 13.4 | 6.7 | 8.7 | 4.3 | |

| Inlet Pressure psi | Outlet Pressure psi | Double Seat Balanced | | Single Seat Balanced* | |
|---|---------------------|----------------------|-------------|-----------------------|-------------|
| | | 1" Valve | 1/16" Valve | 1" Valve | 1/16" Valve |
| 12 | 7" w.c. | 26.2 | 13.1 | — | — |
| | 1/2 psi | 26.0 | 13.0 | — | — |
| | 1 psi | 25.8 | 12.9 | 16.7 | 8.3 |
| | 2 psi | 25.6 | 12.8 | 16.6 | 8.3 |
| | 3 psi | 25.2 | 12.6 | 16.3 | 8.2 |
| | 4 psi | 24.4 | 12.2 | 15.8 | 7.9 |
| | 6 psi | 22.2 | 11.1 | 14.4 | 7.2 |
| | 8 psi | 19.0 | 9.5 | 12.3 | 6.1 |
| | 10 psi | 14.0 | 7.0 | 9.1 | 4.5 |
| | 15 | 1 psi & less | 29.4 | 14.7 | 19.1 |
| 2 psi | | 29.2 | 14.6 | 18.9 | 9.4 |
| 3 psi | | 29.0 | 14.5 | 18.8 | 9.4 |
| 4 psi | | 28.6 | 14.3 | 18.6 | 9.3 |
| 6 psi | | 27.2 | 13.6 | 17.6 | 8.8 |
| 8 psi | | 25.0 | 12.5 | 16.2 | 8.1 |
| 20 | 10 psi | 22.2 | 11.1 | 14.4 | 7.2 |
| | 3 psi & less | 34.6 | 17.3 | 22.5 | 11.2 |
| | 6 psi | 34.0 | 17.0 | 22.1 | 11.0 |
| | 8 psi | 32.8 | 16.4 | 21.3 | 10.6 |
| 25 | 10 psi | 31.4 | 15.7 | 20.4 | 10.2 |
| | 6 psi & less | 39.6 | 19.8 | 25.7 | 12.8 |
| | 8 psi | 39.2 | 19.6 | 25.4 | 12.7 |
| 10 psi & less | 10 psi | 38.4 | 19.2 | 24.9 | 12.4 |
| | 30 | 44.4 | 22.2 | 28.8 | 14.4 |
| | 40 | 54.4 | 27.2 | 35.3 | 17.6 |
| | 50 | 64.4 | 32.2 | 41.8 | 20.9 |
| | 60 | 74.4 | 37.2 | 48.3 | 24.1 |
| | 80 | 94.2 | 47.1 | 61.2 | 30.6 |
| | 100 | 114 | 57.2 | 74.3 | 37.1 |
| | 125 | 139 | 69.6 | 90.4 | 45.2 |
| | 150 | 164 | 82.0 | 106 | 53.3 |
| | 175 | 189 | 94.8 | 123 | 61.6 |
| "K" Factors Standard Valves | | 2000 | 1000 | 1300 | 650 |
| "K" Factors For V-Port Valves, multiply table by: | | .750 | N/A | .750 | N/A |

The single seat balanced valve should not be used for outlet pressures below 1 psi.

Size each regulator on the basis of the minimum expected inlet pressure and the maximum required outlet pressure.

If greater capacity is required, refer to Model 441-S (Bulletin R-1350).

Expanded Outlet Line

These flow rates represent the amount of gas the regulator can actually pass at the given pressure reduction. This amount often exceeds the amount a 2" outlet line can take away, and the flow is restricted to the line capacity.

To take advantage of the regulator's capacity, make certain the outlet line has equal capacity, and increase the line size at the regulator's outlet as necessary, to secure adequate capacity.

Note: The above performance data is based on normal testing at 70° flowing temperature. Changes in performance can occur at extreme low flowing temperatures.

Relief Valves and Back Pressure Valves

For those applications which require a higher degree of accuracy and sensitivity than is possible with standard poppet type reliefs, use the Model 461-SR.

Essentially, it's a regulator arranged to provide inlet pressure control.

When operating as a relief valve, it limits inlet pressure to a set maximum. At pressures below this, it remains closed. If the pressure should attempt to exceed this, it opens and bleeds off the excess.

As a back pressure valve, it prevents gas from exiting from a system until the system pressure reaches the set point. At set point it begins to open and then regulates the discharge so as to hold the system at set point.

Relief Pressure Range

3" w.c. to 10 psi (for range of each spring and diaphragm combination, see table, Page 3.)

Installation

1. Install in line as shown with pressure connected to side marked INLET.
2. For gas, pipe outlet to safe discharge point.
3. Connect inlet line to 1/4" union.
4. By turning adjustment screw, set valve to open at desired pressure. Turning clockwise increases opening pressure.

The 461-SR is the same as the 461-S except that the inner valve is reversed, the body is turned around, and the control line is arranged for connection to the inlet sign (upstream).

The Model 461-SR offers these advantages: (1) accurate setting and control at low relieving pressure because of large, sensitive diaphragm; (2) tight shutoff without leakage due to soft-seat valve construction; (3) large relieving capacity due to large size double valves.

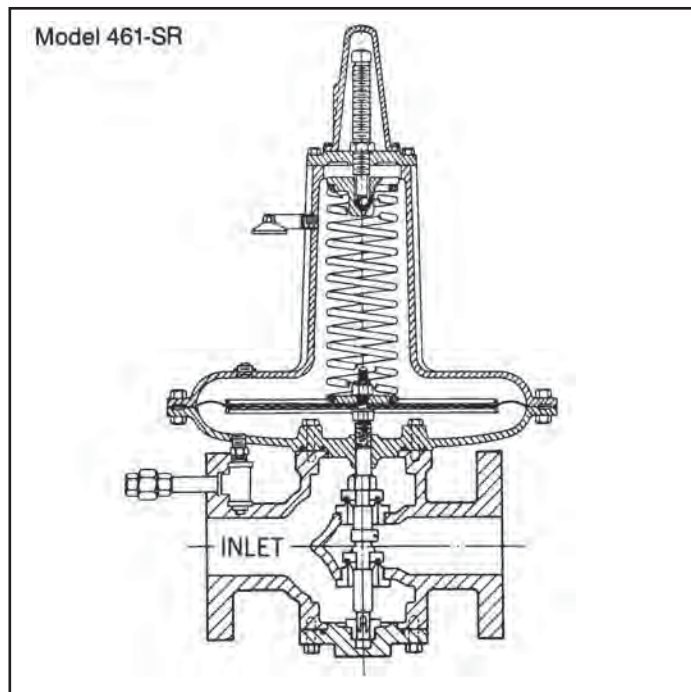

Overpressurization Protection

Protect the downstream piping system and the regulator's low pressure chambers against overpressurization (due to possible regulator malfunction or failure) to achieve complete

lockup. The allowable outlet pressure is the lowest of the maximum pressures permitted by federal codes, state codes, Sensus Bulletin RDS-1498, or other applicable standards.

The method of protection can be a relief valve, monitor regulator, shutoff device, or similar mechanism.

Maximum Emergency Pressures

For complete Maximum Emergency Pressure information for Model 461 regulators, refer to Sensus Bulletin RDS-1498, Regulator Pressure Ratings. If the maximum outlet pressure is exceeded, the regulator must be

removed from service and carefully inspected. Damaged or otherwise unsatisfactory parts must be replaced before returning the regulator to service.

Periodic Inspection: Regulators are pressure control devices with numerous moving parts subject to wear that are dependent upon particular operating conditions. To assure continuous satisfactory operation, a periodic inspection schedule must be adhered to with the frequency of inspection determined by the severity of service and applicable laws and regulations. See Bulletin RM-1330 for field service instructions.



Materials of Construction

| | |
|---|---|
| Diaphragm Housing, Spring Cage (461-S) | Cast Iron (ASTM A126-71 Class B) |
| Diaphragm Housing, Spring Case (461-8S, 461-12S) | Aluminum |
| Diaphragm Plates | Steel |
| Diaphragm | Buna-N with Nylon Fabric Reinforcement |
| Valve Stems | Brass or Stainless Steel |
| Removable Seats (Orifice) | Brass or Stainless Steel |
| Soft Seat Valve Material | Buna-N or Polyurethane pressure molded in holder |
| Holder for Molded Valve | Steel |
| Valve Retainer | Brass or Stainless Steel |
| Bodies | See table, on Pages 11 and 12 |

Monitoring

The 461-S, 461-8S, or 461-12S make an excellent monitor; a standby regulator installed in series which assumes control if a failure in the operating regulator permits the outlet pressure to exceed the set point.

The fast rate of response enables it to take over quickly where necessary, and its outstanding performance means that it will provide excellent standby regulation.

It can be located in either the upstream or the downstream position.

When a 461 is used to monitor a regulator with an identical inner valve (another 461, a Model 1100, etc.) the **total maximum capacity** through both can be figured at 70% of the capacity of one of them alone. This applies with the monitor located either upstream or downstream.

Capacities at Other Pressures

Capacity for pressures not listed in the table on Page 6 can be calculated with the following formulae:

$$1. Q = K\sqrt{P_o(P_i - P_o)}$$

$$2. Q = \frac{KP_i}{2}$$

Q = maximum capacity of the regulator (in SCFH of 0.6 specific gravity natural gas.)

K = the "K" factor, the regulator constant (from the table)

P_i = **absolute** inlet pressure (psia)

P_o = **absolute** outlet pressure (psia)

Use formula 1. when $\frac{P_i}{P_o}$ is less than 1.894.

Use formula 2. when $\frac{P_i}{P_o}$ is greater than 1.894.

Metrication

Use the following for metric conversions:

| |
|--|
| std. meters ³ /hr. x 35.31 = std. ft. ³ /hr. (SCFH) |
| std. ft. ³ /hr. (SCFH) x 0.0283 = std. meters ³ /hr. |
| kilograms/centimeters ² (kg/cm ²) x 14.22 = psig |
| psig x 0.0703 = kilograms/centimeters ² (kg/cm ²) |
| kilopascals (kPa) x 0.145 = psig |
| psi x 6.90 = kilopascals (kPa) |
| bars x 14.50 = psig |
| psig x .069 = bars |
| millimeters water (mm H ₂ O) x .0394 = in. w.c. |
| in. w.c. x 25.4 = millimeters water (mm H ₂ O) |
| millimeters mercury (mm Hg) x 0.535 = in. w.c. |
| in. w.c. x 1.868 = millimeters mercury (mm Hg) |

Other Gases

461-S, 461-8S and 461-12S regulators are mainly used on natural gas. However, they perform equally well on LP gas, nitrogen, dry CO₂, air and others.

For use with gases not listed, please contact your Sensus representative or industrial distributor for recommendations.

| OTHER GASES | CORRECTION FACTOR |
|---|---|
| Air (Specific Gravity 1.0) | 0.77 |
| Propane (Specific Gravity 1.53) | 0.63 |
| 1350 BTU Propane-Air Mix (1.20) | 0.71 |
| Nitrogen (Specific Gravity 0.97) | 0.79 |
| Dry Carbon Dioxide (Specific Gravity 1.52) | 0.63 |
| For other noncorrosive gases: CORRECTION FACTOR= | $\sqrt{\frac{0.6}{\text{Specific Gravity of the Gas}}}$ |

How to Order

- 2" Model 461-S, 461-12S or 461-8S.
- Body Type (see table, on Page 10).
- Outlet Pressure and Spring (see table, Page 2).
- Inlet Pressure (also, minimum and maximum inlet pressures, if available).
- Capacity required (SCFH).
- Type of Gas (natural gas, propane, etc.).
- Trim (brass or stainless steel).
- Valve size (1" or 1/2").
- Double seat or single seat (see Pages 8 and 9)-if not specified, double seat will be furnished.

To Order Parts, Specify:

- Pipe size and model number of regulator.
- Serial number of regulator (if available) or other identifying information.
- Part number and name of part.
- Quantity.
- For orifices and valve parts-specify size of valve (1" or 1/2") and trim (brass or stainless steel).
- For diaphragm, diaphragm plates, or upper or lower covers-specify material and size (12" Al., 8" Al., 12" Cl or 8 1/2" Cl).
- For springs-specify color and part number.

Part numbers and names can be found in Bulletin RM-1330.

Model 461 Balanced Valves

Fully Interchangeable Valve Assemblies

Valve assemblies can be interchanged with the regulator in place in the line.

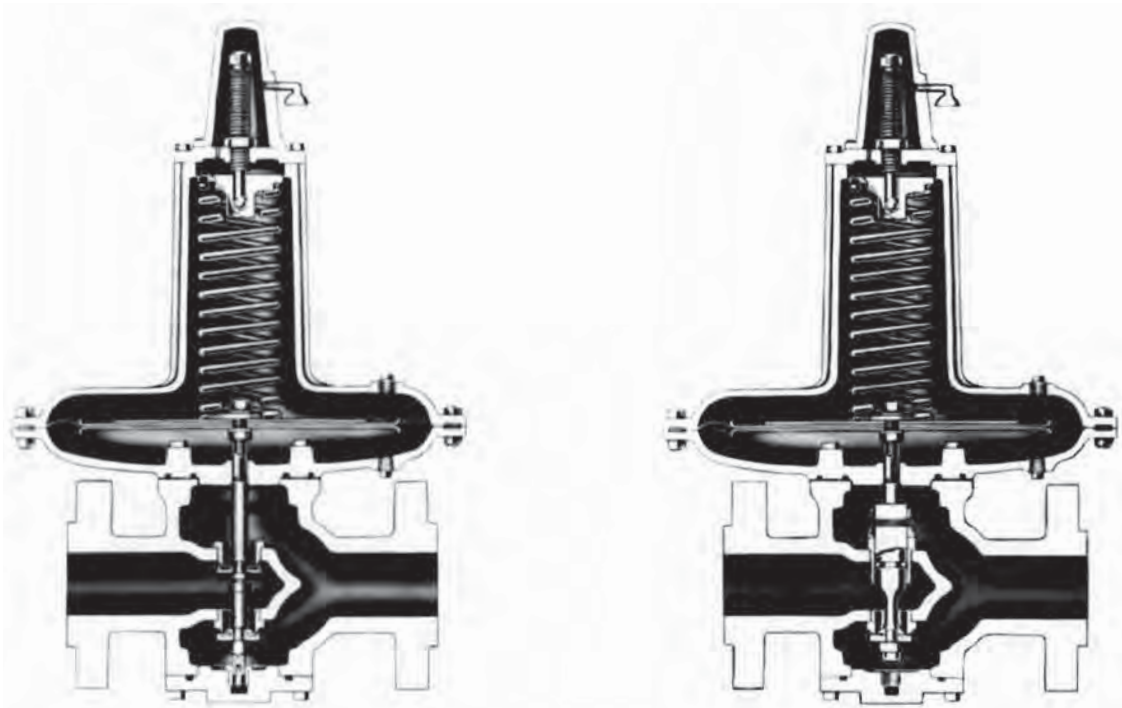

461-S with Double Seat Balanced Valve

461-S with Single Seat Balanced Valve

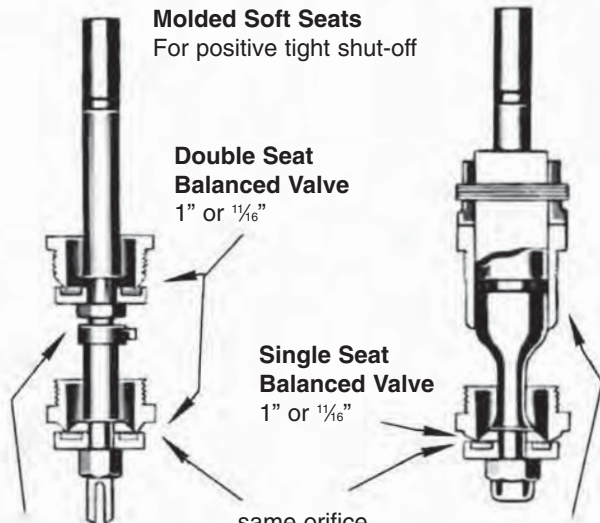

1" Valve is available with V-Port retainers which provide greater turndown performance

Caution: Turn gas on slowly. If an outlet stop valve is used, it should be opened first. Do not over load the diaphragm with a sudden surge of inlet pressure. Monitor the outlet pressure during start-up to prevent an outlet pressure overload. Refer to RM-1330 for more detailed start-up procedures.

Other 461 Models for
Distribution Systems
and Industrials

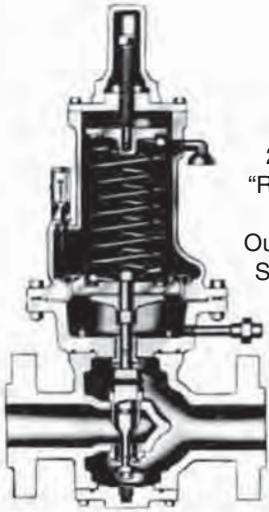

2" Model 461-57S
"Roll-Out" Diaphragm
Regulator
Outlets of 3 to 100 psi
See Bulletin R-1331

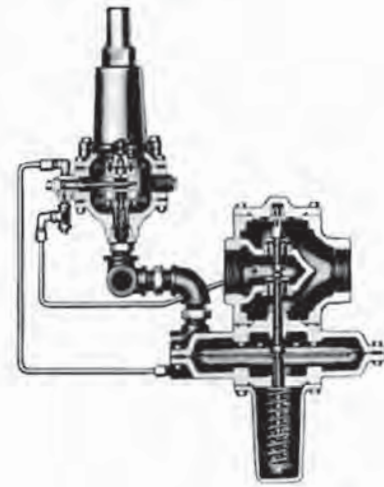

2" Model 1100
Pilot Operated
Regulator
See Bulletin R-1341

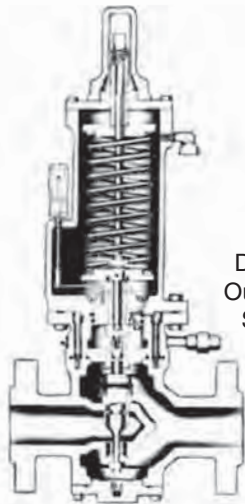

2" Model 461-X57
High-Pressure
"Roll-Out"
Diaphragm Regulator
Outlets of 75 to 250 psi
See Bulletin R-1332

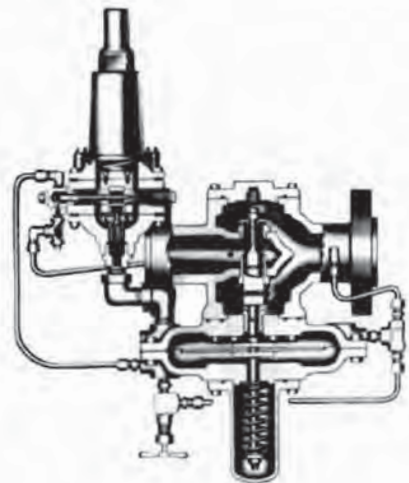

2" Model 1200
All steel construction
Outlets to 600 psi
See Bulletin R-1342

Caution: It is the user's responsibility to assure that all regulator vents and/or vent lines exhaust to a non-hazardous location away from any potential sources of ignition. Refer to Sensus Bulletin RM-1330 for more detailed information.

Dimensions

Model 461-S

| Regulator Body Type | A | B | C | D (12") | D (8 1/2") | Shipping Weight Lbs. | Body Material |
|---------------------|---------|--------|---------|---------|------------|----------------------|---|
| Screwed End | 6 1/2" | | 19 1/2" | 14 1/4" | 11" | 75 | Cast Iron (ASTM A126-71 class B) |
| Flanged 125 lbs. | 10" | 5 1/4" | 19 1/2" | 14 1/4" | 11" | 80 | Cast Iron (ASTM A126-71 class B) |
| Flanged 250 lbs. | 10 1/2" | 5 1/2" | 19 1/2" | 14 1/4" | 11" | 85 | Ductile Iron (ASTM A395-71 gr 60-40-18) |
| Flanged 300 lbs. | 10 1/2" | 5 1/2" | 19 1/2" | 14 1/4" | 11" | 90 | Cast Steel (ASTM A216-70a gr WCB) |

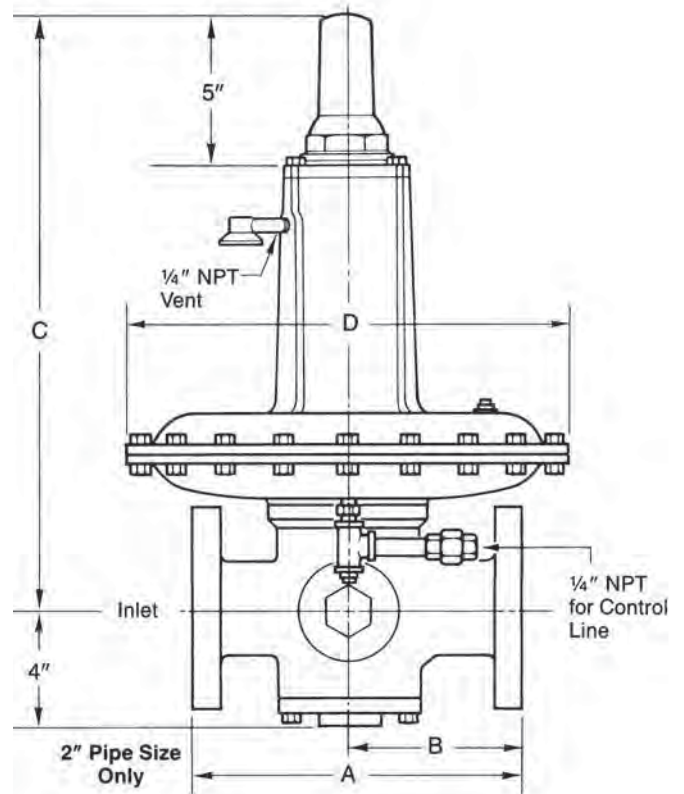

Model 461-8S

| Regulator Body Type | A | B | C | D (12") | Shipping Weight Lbs. | Body Material |
|---------------------|---------|--------|---------|---------|----------------------|---|
| Screwed End | 6 1/2" | | | 10 3/8" | 75 | Cast Iron (ASTM A126-71 class B) |
| Flanged 125 lbs. | 10" | 5 1/4" | 18 3/8" | 10 3/8" | 80 | Cast Iron (ASTM A126-71 class B) |
| Flanged 250 lbs. | 10 1/2" | 5 1/2" | 18 3/8" | 10 3/8" | 85 | Ductile Iron (ASTM A395-71 gr 60-40-18) |
| Flanged 300 lbs. | 10 1/2" | 5 1/2" | 18 3/8" | 10 3/8" | 90 | Cast Steel (ASTM A216-70a gr WCB) |

Model 461-12S

| Regulator Body Type | A | B | C | D (12") | Shipping Weight Lbs. | Shipping Body Material |
|---------------------|---------|--------|---------|---------|----------------------|---|
| Screwed End | 6 1/2" | | | 14" | 75 | Cast Iron (ASTM A126-71 class B) |
| Flanged 125 lbs. | 10" | 5 1/4" | 13 1/4" | 14" | 80 | Cast Iron (ASTM A126-71 class B) |
| Flanged 250 lbs. | 10 1/2" | 5 1/2" | 13 1/4" | 14" | 85 | Ductile Iron (ASTM A395-71 gr 60-40-18) |
| Flanged 300 lbs. | 10 1/2" | 5 1/2" | 13 1/4" | 14" | 90 | Cast Steel (ASTM A216-70a gr WCB) |



805 Liberty Boulevard
DuBois, PA 15801
www.sensus.com

Authorized Distributor:

LIMITED WARRANTY Seller warrants the Goods to be free from defects in materials manufactured by Seller and in Seller's workmanship for a period of [one (1) year] after tender of delivery (the "Warranty Period"). **THIS LIMITED WARRANTY (a) IS IN LIEU OF, AND SELLER DISCLAIMS AND EXCLUDES, ALL OTHER WARRANTIES, STATUTORY, EXPRESS OR IMPLIED, INCLUDING, WITHOUT LIMITATION, ANY WARRANTY OF MERCHANTABILITY OR FITNESS FOR A PARTICULAR PURPOSE, OR OF CONFORMITY TO MODELS OR SAMPLES; (b) does not apply to any Goods which have been (i) repaired, altered or improperly installed; (ii) subjected to improper use or storage; (iii) used or incorporated with other materials or equipment, after Buyer or anyone using the Goods has, or reasonably should have, knowledge of any defect or nonconformance of the Goods; or (iv) manufactured, fabricated or assembled by anyone other than Seller; (c) shall not be effective unless Buyer notifies Seller in writing of any purported defect or nonconformance within [thirty (30) days] after Buyer discovers or should have reasonably discovered such purported defect or nonconformance; and (d) shall only extend to Buyer and not to any subsequent buyers or users of the Goods. Buyer shall provide Seller access to the Goods as to which Buyer claims a purported defect or nonconformance; upon request by Seller, Buyer shall, at its own risk and expense, promptly return the Goods in question to Seller's Plant.**