

# Model 461-X57

High Pressure Regulators  
with Roll-Out Diaphragm



**Equimeter**  
INCORPORATED

A BTR Metering Systems Company

Taking the measure of tomorrow

# Model 461-X57 High Pressure Regulators with "Roll-Out Diaphragm"

## The "Roll-Out Diaphragm"

The 461-X57 is something unique in a high pressure regulator. It features the same "Roll-Out" diaphragm principle that has achieved such remarkable success in the widely used 441-57S and 461-57S Regulators.

The 461-X57 offers pilot performance with spring regulator simplicity. The "Roll-Out" diaphragm makes this outstanding performance possible by minimizing that old gremlin, "droop."

"Droop" means rough regulation . . . wide fluctuation

in pressure control as flow varies. It is the result of spring effect plus diaphragm effect.

The "Roll-Out" diaphragm changes this by eliminating diaphragm effect and neutralizing spring effect, thus, "droop" is reduced to insignificance. The result — smooth, constant pressure regulation. It comes amazingly close to the control performance of the pilot operated regulator.

Figure 1 shows how the "Roll-Out" diaphragm works. Figure 2 shows how close

performance comes to that of a pilot operated regulator. And the cutaway picture on Page 4 shows how simple it is.

Speed of response is fast. Installation, adjustment and servicing are surprisingly easy. The hazard of shutoff from pilot freeze-up is eliminated. And, to top it off, the ingenious ball-check diaphragm sentry (Figure 3, this page) adds yet another feature to a list that makes the 461-X57 truly a remarkable high pressure regulator.

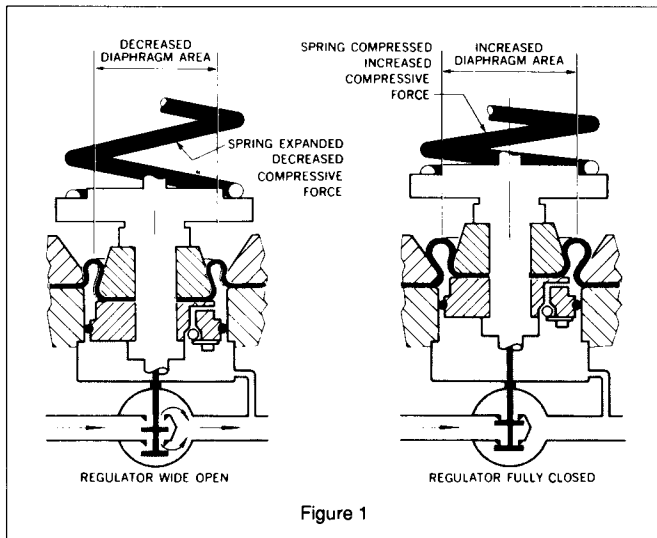

Figure 1

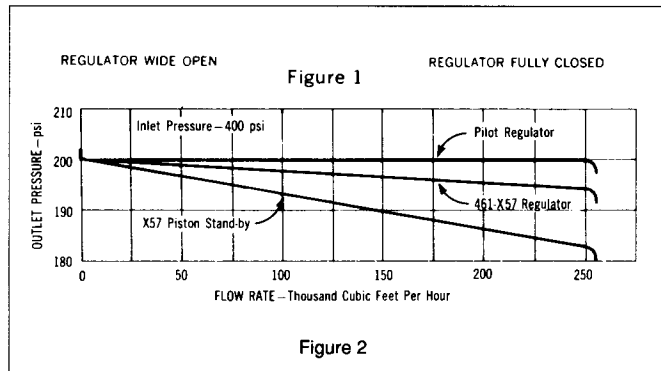

Figure 2

## Ball-Check Diaphragm Sentry

The ball-check diaphragm sentry is a safety device for keeping the regulator in operation in case of diaphragm failure.

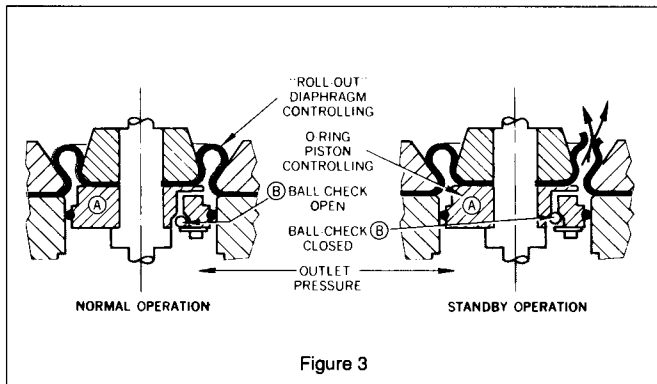

Figure 3

Referring to Figure 3, this is how it works:

1. O-ring piston (A) holds the Roll-Out diaphragm in correct alignment during normal operation.
2. Ball-check (B) is normally open to put outlet pressure against the Roll-Out diaphragm.
3. If a break should occur in the diaphragm, outlet pressure gas instantly begins to escape through the break and out the vent to atmosphere. This escaping gas flow immediately closes (B).

4. The closing of (B) also prevents the diaphragm break from allowing gas to escape through the vent.
5. Regulation with the O-ring piston will show increased deviation from set-point. This deviation is the warning that a failure has occurred.

Maximum Inlet Pressure	Regulator Body Type	461 Body Materials	Maximum Working Pressure of Body	Maximum Inlet Pressure
	Flanged ANSI 250 RF	Ductile Iron (ASTM A395-71 gr 60-40-18)	575 psi	575 psi
	Flanged ANSI 300 RF	Cast Steel (ASTM A216-70a gr WCB)	720 psi	720 psi
	Flanged ANSI 600 RF	Cast Steel (ASTM A216-70a gr WCB)	1200 psi	1000 psi

Maximum Pressure Differential and Maximum Inlet Pressure for Various Soft-Seated Valve Materials*	Valve Material	Maximum Pressure Differential	Maximum Inlet Pressure
	Buna-N (black, 50 to 550 duro)	250 psi	575 psi
	Polyurethane (red, 65 to 75 duro)	400 psi	720 psi
	Polyurethane (tan, 85 to 95 duro)	600 psi	1000 psi

\* The differential and inlet pressures given are only to be used as general guidelines. In all cases, pressures must always remain within the ranges specified in Equimeter literature. For any given regulator, do not exceed the specified maximum pressures.

The maximum temperature for the above materials is 150°F.

Viton valve material has a maximum temperature rating of 300°F and a maximum pressure differential of 250 psi.

Spring Ranges	Outlet Pressure Ranges	Spring Color	Spring Part Number
	75 to 100 psi	Red	091-00-021-02
	100 to 175 psi	Brown	091-00-021-01
	150 to 250 psi	Black	091-00-021-00

### Typical Installation

The simple and compact design of the Model 461-X57 makes it an easy regulator to install. The sketch below shows a typical arrangement. The regulator will work to

deliver the pressure, for which it is adjusted, at that point in the downstream system where the downstream control line connection is made. As a general rule, it should be at least 8 pipe diameters downstream from the regulator and should be located in as straight a run of pipe as possible. Where outlet piping increases in size near the regulator, it is preferable to connect into the larger diameter portion. The connection itself must be smooth and clean, free of rough edges, welding icicles, etc.

**Caution:** It is the user's responsibility to assure that a service regulator vents and/or vent lines exhaust to a non-hazardous location away from any potential sources of ignition. Refer to Equimeter Bulletin RM-1332 for more detailed information.

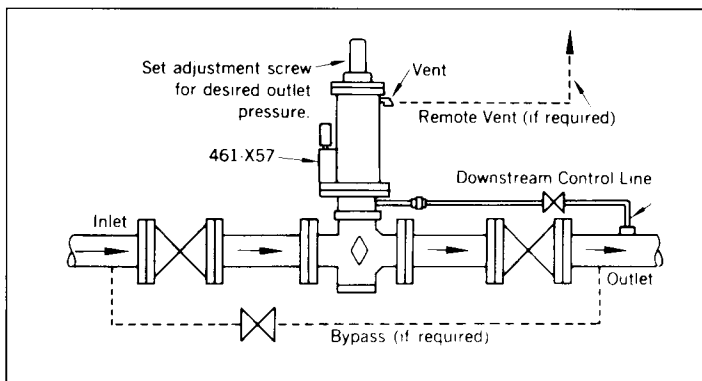

### Pipe Sizes

Inlet x Outlet NPT
2" Model Available Only

### Temperature Limits

The Model 461-X57 Service Regulators can be used for temperatures from -20°F. to 150°F.

### Buried Service

The Model 461-X57 Regulator is *not* recommended for buried service.

**Caution:** Turn gas on slowly. If an outlet stop valve is used, it should be opened first. Do not overload the diaphragm with a sudden surge of inlet pressure. Monitor the outlet pressure during start-up to prevent an outlet pressure overload. See Bulletin RM-1332 for more detailed start-up procedures.

# Construction and Design Features

## 461-X57 High-Pressure Regulators

INTERMEDIATE CAPACITY  
For

- High Pressure Regulator Sets
- Gas Distribution Systems
- Town Border Stations
- Transmission Systems
- Monitoring
- High Pressure Industrial Applications

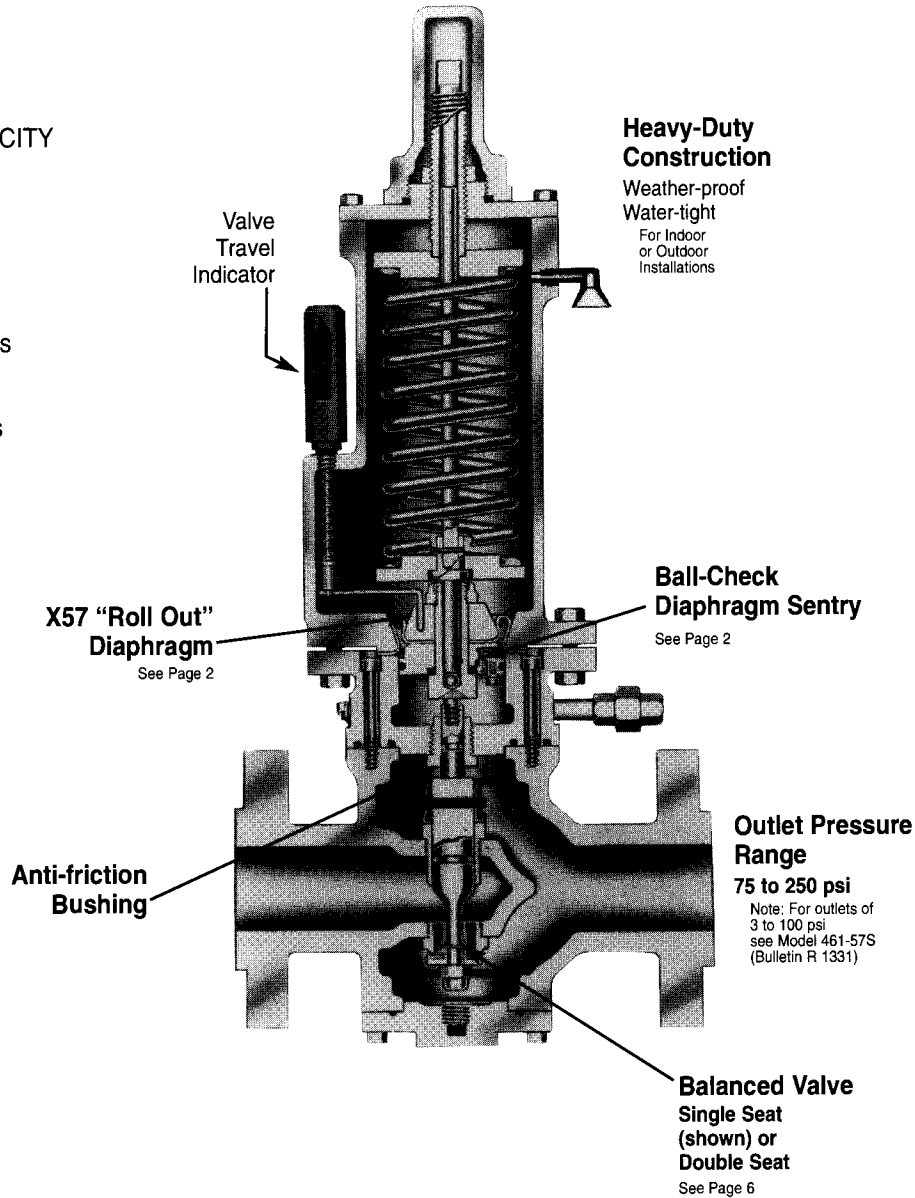

### Other Features

**Simple Design** – dependable regulation – trouble free operation – fast response – no pilot – no pilot freezing – no pilot maintenance.

**Standard Face to Face Dimensions**

**Standardized “461” Bodies & Inner Valve Assemblies** – easy maintenance – parts are interchangeable with other 461 models.

**Simplified Valve Adjustment** – easy to adjust for tight lock-up – accurate.

**Molded Polyurethane Soft Seats** – positive tight shut-off – high erosion resistance – will not blow out.

**O-Ring Stem Seal** – with removable anti-friction bushing.

**Bushing Guided Inner Valve** – accurate stem alignment and valve seating.

**Side Inspection Plates** – both sides of body – quickly removable.

**O-Ring Body Seals** – eliminates gaskets on upper and lower openings and side inspection plates.

**Self-Aligning Spring Assembly** – color coded springs.

# Model 461-X57 Capacity Table



## Capacity 461-X57 in 1000 scfh of natural gas (0.6) specific gravity - 14.65 psia - 60°F.)

Inlet Pressure psi	Outlet Pressure psi	Double Seat Balanced		Single Seat Balanced	
		1" Valve	1 1/16" Valve	1" Valve	1 1/16" Valve
80	75	42.2	21.1	27.4	13.7
85	75	59.8	29.9	38.8	19.4
	80	43.4	21.7	28.2	14.1
90	75	73.2	36.6	47.5	23.8
	80	61.4	30.7	39.9	19.9
	85	44.6	22.3	29.0	14.5
100	75	94.6	47.3	61.5	30.7
	80	86.8	43.4	56.4	28.2
	85	77.2	38.6	50.1	25.1
	90	64.6	32.3	42.0	21.0
110	75	112.0	56.0	72.8	36.4
	80	106.0	53.2	69.1	34.5
	90	91.4	45.7	59.4	29.7
	100	67.6	33.8	43.9	21.9
120	75	127.0	63.5	82.5	41.2
	80	122.0	61.4	79.8	39.9
	90	112.0	56.0	72.8	36.4
	100	95.6	47.8	62.1	31.0
	110	70.6	35.3	45.9	22.9
140	75	152.0	76.3	99.2	49.6
	80	150.0	75.3	97.9	48.9
	90	144.0	72.2	93.8	46.9
	100	135.0	67.6	87.8	43.9
	120	103.0	51.8	67.3	33.6
160	80 & Less	174.0	87.2	113.0	56.6
	90	171.0	85.5	111.0	55.5
	100	165.0	82.8	107.0	53.8
	120	146.0	73.3	95.3	47.6
	140	111.0	55.6	72.2	36.1
180	90 & Less	194.0	97.2	126.0	63.1
	100	191.0	95.7	124.0	62.2
	120	179.0	89.8	116.0	58.3
	140	157.0	78.6	102.0	51.1
	160	118.0	59.1	76.8	38.4
200	100 & Less	214.0	107.0	139.0	69.6
	120	207.0	103.0	134.0	67.4
	140	192.0	96.2	125.0	62.5
	160	167.0	83.5	108.0	54.2
	180	124.0	62.4	81.1	40.5
225	110 & Less	239.0	120.0	155.0	77.8
	120	237.0	119.0	154.0	77.2
	140	229.0	114.0	149.0	74.5
	160	213.0	106.0	138.0	69.2
	180	187.0	93.6	121.0	60.8
200	146.0	73.2	95.1	47.5	

Inlet Pressure psi	Outlet Pressure psi	Double Seat Balanced		Single Seat Balanced	
		1" Valve	1 1/16" Valve	1" Valve	1 1/16" Valve
250	125 & Less	264.0	132.0	171.0	85.9
	140	260.0	130.0	169.0	84.7
	160	250.0	125.0	162.0	81.4
	180	233.0	116.0	151.0	75.8
	200	207.0	103.0	134.0	67.2
	225	154.0	77.3	100.0	50.2
275	140 & Less	289.0	144.0	188.0	94.0
	160	283.0	141.0	184.0	92.1
	180	271.0	136.0	176.0	88.3
	200	253.0	126.0	164.0	82.4
	225	218.0	109.0	142.0	71.1
300	150 & Less	314.0	157.0	204.0	102.0
	175	307.0	154.0	200.0	100.0
	200	292.0	146.0	190.0	95.1
	225	268.0	134.0	174.0	87.1
	250	230.0	115.0	146.0	74.7
325	165 & Less	339.0	169.0	220.0	110.0
	180	335.0	168.0	218.0	109.0
	200	327.0	163.0	212.0	106.0
	225	309.0	154.0	201.0	100.0
	250	281.0	140.0	183.0	91.5
350	180 & Less	365.0	182.0	236.0	118.0
	200	358.0	179.0	233.0	116.0
	225	346.0	173.0	225.0	112.0
	250	325.0	162.0	211.0	105.0
400	205 & Less	414.0	207.0	269.0	134.0
	225	409.0	204.0	266.0	133.0
	250	398.0	199.0	258.0	129.0
450	230 & Less	464.0	232.0	301.0	151.0
	250	460.0	230.0	299.0	149.0
500	250 & Less	514.0	257.0	334.0	167.0
550	250 & Less	564.0	282.0	366.0	183.0
600	250 & Less	614.0	307.0	399.0	199.0
700	250 & Less	714.0	357.0	464.0	232.0
800	250 & Less	814.0	407.0	529.0	264.0
1000	250 & Less	1014.0	507.0	659.0	329.0
<b>"K" Factors</b>		<b>2000</b>	<b>1000</b>	<b>1300</b>	<b>650</b>

1. Size each regulator on the basis of the minimum expected inlet pressure and the maximum required outlet pressure
2. For best performance of the Model 461-X57, use full table capacity values.
3. For lower capacities see Models 040/141 (Bulletins R-1310 & R-1311).

**Note:** The above performance data is based on normal testing at 70°F flowing temperature. Changes in performance can occur at extreme low flowing temperatures.

# Type 461 Balanced Valves

## Fully Interchangeable Valve Assemblies

Valve assemblies can be interchanged with the regulator in place in the line.

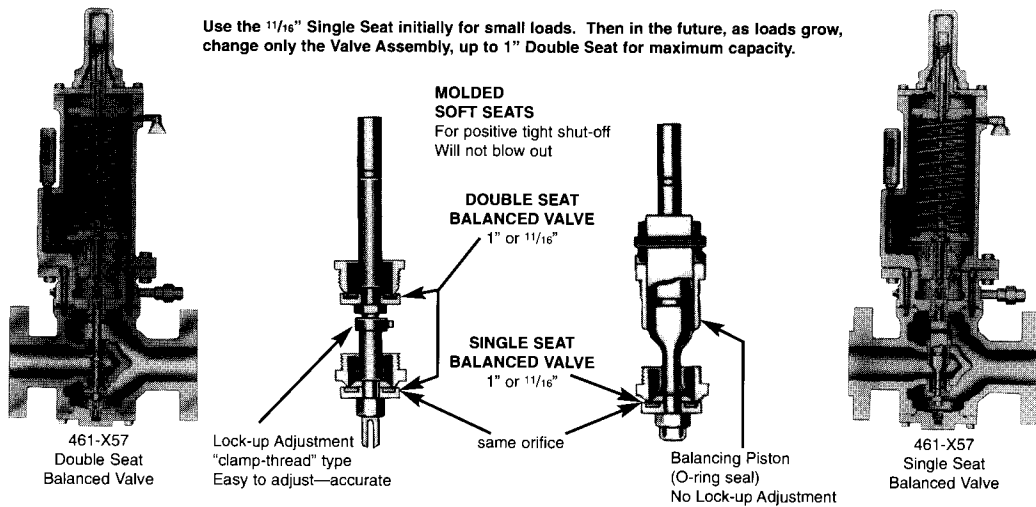

## The 461 Family of Regulators

Other models which use Type 461 balanced valves

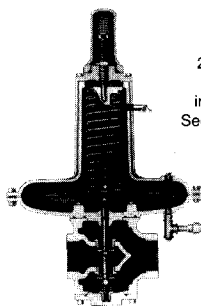

2" Model 461-S  
Outlets  
in. w.c. to 10 psi  
See Bulletin R 1330

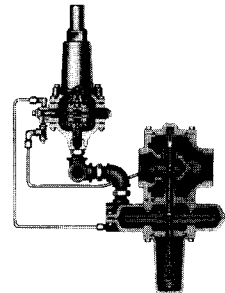

2" Model 1100  
Outlets  
in. w.c. to 100 psi  
See Bulletin R 1341

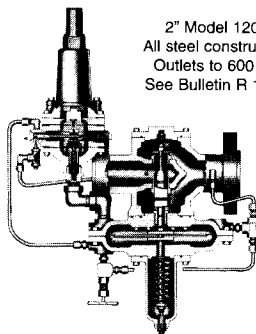

2" Model 1200  
All steel construction  
Outlets to 600 psi  
See Bulletin R 1342

2" Model 461-57S  
"Roll-Out Diaphragm"  
Outlet Pressures  
3 to 100 psi  
See Bulletin R 1331

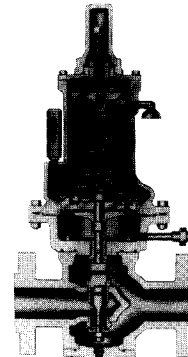

## Maximum Emergency Pressures

The maximum pressure the regulator inlet may be subjected to under abnormal conditions without causing damage to the regulator is:

Ductile Iron,  
Flanged ANSI 250...630 psi  
Cast Steel,  
Flanged ANSI 300...800 psi  
Cast Steel,  
Flanged ANSI 600...1100 psi

The maximum pressure the outlet may be subjected

without causing damage to the internal parts of the regulator is:

All 461-X57.....set-point + 50 psi

Set-point is defined as the outlet pressure a regulator is adjusted to deliver.

If any of the above pressure limits are exceeded, the regulator must be taken out of service and inspected. Damaged or otherwise unsatisfac-

tory parts must be repaired or replaced.

The maximum pressure that can be safely contained by the diaphragm case is:

All 461-X57.....350psi

Safely contained means no leakage as well as no bursting.

Before using any of the above data, make sure this entire section is clearly understood.

## Overpressurization Protection

Protect the downstream piping system and the regulator's low pressure chambers against overpressurization due to the possible regulator malfunction or fail-

ure to achieve complete lockup. The allowable outlet pressure is the lowest of the maximum pressures permitted by federal codes, state codes, Equimeter Bul-

letin RDS-1498, or other applicable standards. The method of protection can be a relief valve, monitor regulator, shutoff device, or similar mechanism.

## Capacities at Other Pressures

Capacity for pressure reductions not listed in the table can be calculated with the following formulae:

$$1. Q = K \sqrt{P_o (P_i - P_o)}$$

$$2. Q = \frac{K P_i}{2}$$

Q = maximum capacity of the regulator (in SCFH of 0.6 specific gravity natural gas).

K = the "K" factor, the regulator constant (from bottom of table, page 5).

P<sub>i</sub> = absolute inlet pressure (psia).

P<sub>o</sub> = absolute outlet pressure (psia).

Use formula 1. when  $\frac{P_i}{P_o}$  is less than 1.894.

Use formula 2. when  $\frac{P_i}{P_o}$  is greater than 1.894.

**Periodic Inspection:** Regulators are pressure control devices with numerous moving parts subject to wear that is dependent upon particular operating conditions. To assure continuous satisfactory operation, a periodic inspection schedule must be adhered to with the frequency of inspection determined by the severity of service and applicable laws and regulations. **See bulletin RM-1332 for field service instructions.**

# Monitoring

The Model 461-X57 is also excellent for use as a monitor: a stand-by regulator mounted in series which assumes control if a failure in the operating regulator permits the outlet pressure to rise above its set point.

The 461-X57 has a fast rate of response and, therefore, will take control quickly in case of emergency. It requires no changes or modifications to be used for monitoring. Its simple design and rugged construction make it an exceptionally dependable regulator, and its control accuracy and freedom from "droop" mean that it will provide excellent regulation if an emergency calls it into operation.

Two monitor set arrangements are shown in the sketches below. The first shows a set in which the operating regulator and the monitor are both Model 461-X57. This makes a neat and compact installation.

The 461-X57 is also used for monitoring other types of regulators. This is shown in the second sketch. It is excellent for monitoring pilot operated regulators.

Both sketches show the monitor in the downstream

position. When installed this way, the 461-X57 is usually set for an outlet pressure 4 to 6 psi higher than the operating regulator and thus is wide open during normal operation.

The monitor can also be located upstream, and with this arrangement the 461-X57 is usually set for an outlet somewhat higher than the above.

Shutoff and bypass valving varies with individual prac-

tices and requirements. In general, however, the sketch "Typical Installation" on page 3 can be used as a guide for the arrangement of these valves.

When identical 461-X57 Regulators are used for both the operating regulator and the monitor, the total maximum capacity through both may be figured as 70 percent of the capacity of one of them alone. This applies with the monitor located either downstream or upstream.

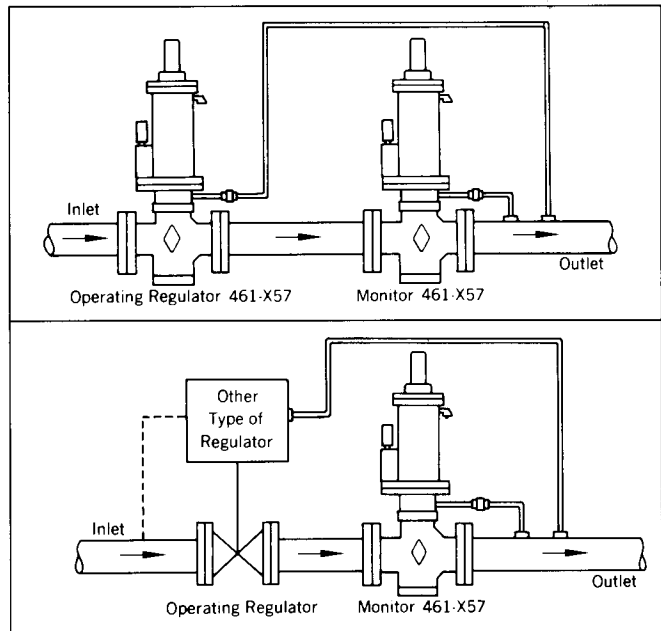

# Metrication

Use the following for metric conversions:

std. metres <sup>3</sup> /hr. x 35.31 = std. ft. <sup>3</sup> /hr (SCFH)
std. ft. <sup>3</sup> /hr (SCFH) x 0.0283 = std. metres <sup>3</sup> /hr.
kilograms/centimeter <sup>2</sup> (kg/cm <sup>2</sup> ) x 14.22 = psig
psig x 0.0703 = kilograms/centimeter <sup>2</sup> (kg/cm <sup>2</sup> )
kilopascals (kPa) x 0.145 = psig
psig x 6.90 = kilopascals (kPa)
bars x 14.50 = psig
psig x 0.69 = bars
millimeters water (mm H <sub>2</sub> O) x .0394 = in. w.c.
in. w.c. x 25.4 = millimeters water (mm H <sub>2</sub> O)
millimeters mercury (mm Hg) x 0.535 = in. w.c.
in. w.c. x 1.868 = millimeters mercury (mm Hg)

Regulator Body Type	A	B	Shipping Weight Lbs.
Flanged ANSI 250 RF	10 <sup>1</sup> / <sub>2</sub>	5 <sup>1</sup> / <sub>2</sub>	85
Flanged ANSI 300 RF	10 <sup>1</sup> / <sub>2</sub>	5 <sup>5</sup> / <sub>8</sub>	88
Flanged ANSI 600 RF	11 <sup>1</sup> / <sub>4</sub>	6	90

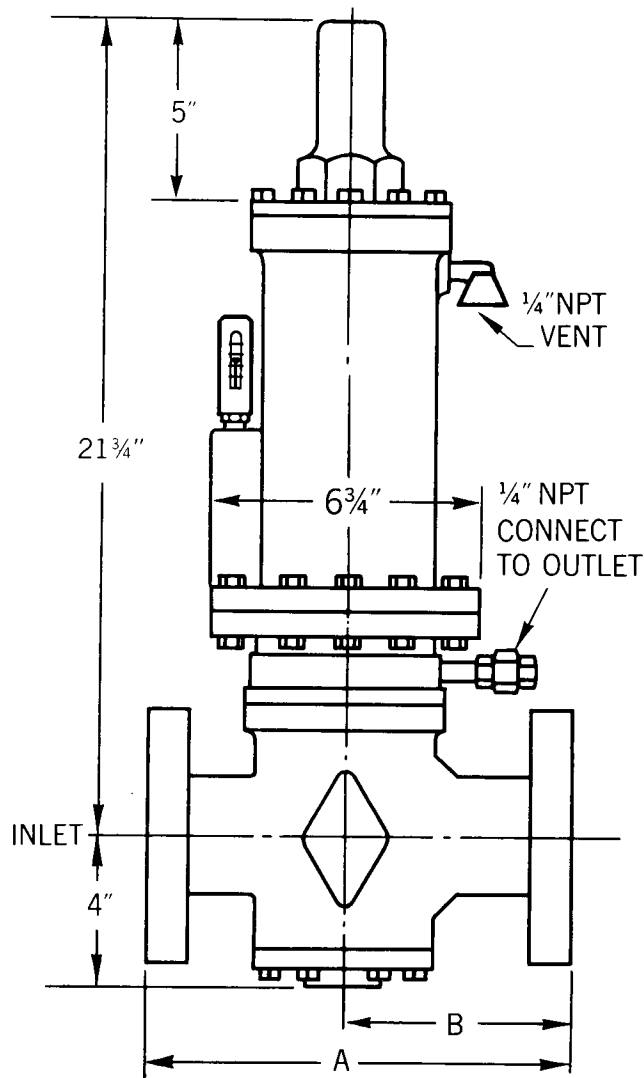

**Caution:** It is the user's responsibility to assure that a service regulator vents and/or vent lines exhaust to a non-hazardous location away from any potential sources of ignition. Refer to Equimeter Bulletin RM-1332 for more detailed information.

## General Information

### Materials of Construction

Diaphragm Housing, Spring Cage .....	Cast Iron (ASTM A126-71 Class B)
Bottom Diaphragm Housing .....	Steel (ASTM A216-70a gr WCB)
Housing Cover (Spring Cage Cap).....	Ductile Iron (ASTM A395-71 gr 60-40-18)
Upper Diaphragm Plate & O-Ring Piston .....	Stainless Steel
Diaphragm .....	Buna-N with Dacron* Reinforcement
Diaphragm Stud.....	Stainless Steel
Removable Seats (Orifices).....	Stainless Steel
Valve Stems .....	Stainless Steel
Soft Seat Valve Material .....	Polyurethane, pressure molded in holder
Holder for Molded Valve .....	Steel
Valve Retainer .....	Stainless Steel
Bodies.....	see table on Page 3

\*Trademark of E.I duPont de Nemours Co Inc

### Other Gases

Model 461-X57 Regulators are mainly used on natural gas. However, they perform well on LP gas, nitrogen, dry CO<sub>2</sub>, air, and others.

The capacity data on page 4 applies to natural gas. To find the capacity of the Model 461-X57 when used with other gases, multiply the SCFH values from page 5 by a correction factor from the following table:

OTHER GASES	CORRECTION FACTOR
Air (Specific Gravity 1.0)	0.77
Propane (Specific Gravity 1.53)	0.63
1350 BTU. Propane-Air Mix (1.20)	0.71
Nitrogen (Specific Gravity 0.97)	0.79
Dry Carbon Dioxide (Specific Gravity 1.52)	0.63
For Other Gases $\text{CORRECTION FACTOR} = \sqrt{\frac{0.6}{\text{Specific Gravity of the Gas}}}$	

### How to Order

Specify:

1. 2" Model 461-X57
2. Piping connections & body material (see table on page 3)
3. Outlet pressure and/or spring (see table on page 3)
4. Inlet pressure, psi (minimum & maximum, if available)
5. Capacity required (scfh)
6. Type of gas (natural gas, propane, etc.)
7. Double seat or single seat and 1" or 1/16" valve (see page 6)

Installation and Maintenance see RM-1332

# Other Equimeter Gas Pressure Regulators



Equimeter produces a broad product line of Gas Pressure Regulators which are widely used throughout the natural gas industry. These regulators are also suitable for non-corrosive industrial gas applications such as propane, butane, air, nitro-

gen, dry CO<sub>2</sub>, etc. For additional detailed information on a particular model, please request the indicated bulletin from the local Equimeter sales office.

## Multi-Purpose Service Regulators

Model Accuro 2000  
Bulletin: R-2000 3/4", 1" pipe size  
Inlet pressures ..... to 125 psi  
Outlet pressures ..... 5" w.c. to 2 psi  
Capacity to 2000 CFH  
Available with 90° body.  
Also available with internal relief valve.

Model 143-80  
Bulletin: R-1301  
3/4", 1", 1 1/4" pipe size  
Inlet pressures ..... to 125 psi  
Outlet pressures ..... 3 1/2" w.c. to 6 psi  
Capacity to 2000 CFH  
Available with straight-through body.  
Also available: internal relief valve and low pressure cut-off.

Model 143-6  
Bulletin: R-1303  
3/4", 1", 1 1/4" pipe size  
Inlet pressures ..... to 125 psi  
Outlet pressures ..... 3 1/2" w.c. to 6 psi  
Capacity to 2000 CFH  
Available with 90° angle or straight-through body.  
Also available: internal relief valve and low pressure cut-off.

## Industrial Service Regulators

Models 243-8, 243-12, 243-8HP  
Bulletin: R-1306  
1 1/4", 1 1/2" and 2" pipe size  
Inlet pressures ..... to 125 psi  
Outlet pressures ..... 3 1/2" w.c. to 10 psi  
Capacity to 25,000 CFH  
Also available: internal relief valve, low pressure cut-off external control line, back pressure regulator, relief valve, vacuum regulator and vacuum breaker.

## Industrial Field Regulators

For intermediate to high pressure applications. Ideal on pipeline taps servicing plants and buildings. Appropriate for double stage reduction ahead of service regulators, and for high pressure burners and compressed air systems.

041, 042  
Bulletin: R-1310  
3/4", 1" and 1 1/4" pipe size  
Inlet pressures ..... to 1000 psi  
Outlet pressures ..... 3 to 200 psi  
Capacity to 40,000 SCFH

141 A  
Bulletin: R-1311  
2" pipe size  
Inlet pressures ..... to 1500 psi  
Outlet pressures ..... 5 to 400 psi  
Capacity to 55,000 SCFH

## Pilot Loaded Regulators

For intermediate and high-pressure applications requiring precise pressure reduction with minimal droop. Ideal for standard and high capacity flows on burners, driers, dehydrators and compressor line. Appropriate for fixed factor billing.

243-RPC  
Bulletin: R-1343  
1 1/4", 1 1/2" and 2" pipe size  
Inlet pressures ..... to 150 psi  
Outlet pressures ..... 3 1/2" w.c. to 35 psi  
Capacity to 76,000 SCFH

11 00  
Bulletin: R-1341  
Pipe size: 2"  
(screwed or flanged)  
Inlet pressures ..... to 400 psi  
Outlet pressures ..... 3" w.c. to 100 psi  
Capacity to 414,000 SCFH

1200  
Bulletin: R-1342  
Pipe size: 2" (flanged)  
Inlet pressures ..... to 1200 psi  
Outlet pressures ..... 20 to 600 psi  
Capacity to 789,000 SCFH

Equimeter also produces Industrial and Combustion Regulators; High Pressure, High Capacity Regulators; and Safety Relief Valves. Detailed information available on request.