



I-Series Rotary Meters



Installation and Maintenance Instructions

January 2003

Table of Contents

General Description.....	3
Packaging and Storage.....	3
Operation.....	4
Installation.....	4
Start-Up.....	7
Inspection and Maintenance.....	7
Changing Meter Flow Direction.....	9
Vertical Meter Installation	10
Horizontal Meter Installation.....	11
Vertical to Horizontal Flow	12
Inlet to Outlet Flow	13
Pressure and Temperature Correction.....	14
Pulse Outputs	14
Meter Dimensions.....	15
Wiring Diagram.....	16
Meter Specifications.....	17
Warranty	18

General Description:

The Invensys Metering Systems I-Series Rotary Meters are positive displacement type measuring meters. That is they utilize the process of alternately filling and emptying compartments of a known quantity of gas. The models **I2.3**, **I3.5**, **I5.6** and **I8.8** comprise the four types of rotary meters, with the model number designating the capacity at 7" w.c. operating pressure. For example, the I2.3 = 2,300 cfh and so on. The I2.3 and I3.5 are **2" ANSI 125 Flat Face Flange** connections. The I5.6 and I8.8 are **3" ANSI 125 Flat Face Flange** connections. The meters can be installed in a wide range of continuous measuring gas applications. The meters are designed for:

- Filter-cleaned gases with a solid grain size of less than 50 microns.
- Dry non-aggressive "common" gases
- Gases at operating temperatures between -40⁰ F to 120⁰ F (-40⁰ C to 120⁰ C)
- Gases at operating pressures between 5" w.c. and 175 psig (12 mbar - 12 bar)
- Constant or continuous varying gas flow rates

I-Series Rotary meters are **not** designed for:

- Dirty, dusty or contaminated gases
- Acetylene, sewage gas or corrosive gases
- Any type of liquids
- Installations where excessive vibration may be present

Meters should be installed in cathodically protected pipelines with isolated flanges. For measurement of any type of combustible gases, the meters should be installed away from potential ignition sources. In addition, all meter installations should be installed away from or provided protection from potential damage from surrounding elements such as cars, fork lifts, etc.

Packaging and Storage

The I-Series Rotary Meters are of robust construction and require reasonable care during handling, shipping, and storage. Upon receipt, inspect the packaging for potential damage. Evidence of shipping damage to the packaging means an increased potential for damage to the meter itself. Therefore, **if there is evidence of damage to the packaging, notify the shipper and immediately perform an inspection of the meter itself. If the meter is damaged, immediately file a claim with the shipper, and notify Invensys Metering Systems of the occurrence.** When inspecting for damage, be sure to check for the free rotation of the impellers by gently blowing into the meter inlet. . **CAUTION: To prevent injury, do not use your fingers to rotate the impellers.** Even though there may be no visual signs of damage to the packaging or/and the meter, the impellers may have been damaged in transit. **Do not attempt to perform any repairs or maintenance on the meter. Return it to Invensys Metering Systems. Attempted repairs can result in voiding warranty claims.**

Meters that are stored should be kept in a dry area, away from any potential damage. The end caps should be kept on the inlet and outlet of the meters. It is best to keep the meter in the original box, which includes the appropriate literature and bottle of lubricating oil. No oil should be added to the meter until the meter is ready to be installed or has already been installed and is ready for service.

Operation

The I-Series Rotary Meters are comprised of a measuring unit and a totalizer. The body casing and end plates form the measuring unit. Within the measuring unit are the measuring chambers, formed by the interlocking rotation of two precision "figure 8" impellers. The impellers are mounted in the end plates using roller bearings. Utilizing a pair of timing gears, each impeller captures a known volume of gas and moves it from the meter inlet to the outlet. The rotary impellers rotate opposite direction to each other without contact to provide this continuous flow of gas through the meter.

The totalizer is located on the one cover end. A magnetic clutch links the rotary impellers and the totalizers. When the gas begins to be used downstream of the meter, a pressure differential results across the meter. A small differential causes the impellers to begin to rotate, and gas flows through the meter. Through the magnetic clutch, the rotation of the impellers is transferred to the totalizer. The totalizer sums the complete revolutions of the impellers, converts this to volume of gas and displays the total on the digital index as cubic feet or cubic meters.

Installation

An appropriately sized I-Series rotary meter model should be selected for the installation. The meter selection is dependent upon the minimum and maximum flow requirements, inlet pressure, and the type of customer gas usage. Detailed sizing instructions are provided on page 5 of literature M-4000. Ensure that the correct meter is chosen before installation. In addition, if an electronic pressure and/or temperature correcting instrument is to be installed on the meter, the meter selected will need to have at least one pulse output provided.

After unpacking a meter, inspect the meter for damage. Remove the end caps and ensure that the impellers rotate smoothly by gentle blowing into the meter. **CAUTION: To prevent injury, do not use your fingers to rotate the impellers.** Visually inspect for any foreign objects in the measuring chamber. Replace the end caps until ready for installation into the pipeline.

A set of black labels with x10, x100, and x1000 are supplied with each meter. If you want to read the gas usage through the meter by a factor of 10, 100 or 1,000, simply cover the corresponding last digits with the cover labels. For example, if you want to read mcf (thousands of cubic feet) of gas, cover the last three odometer digits with the x1000 cover label on the index face as shown below.

0 0 4 5 3 1 7 Cu ft

0 0 4 5 X 1000 Cu ft

Before installations, ensure that the pipeline is free from dirt and contaminants. Valves or other instruments that could result in subjecting the rotary meter to excess lubricants should not be installed directly upstream of the meter. The lubricants or other foreign materials could possibly impede the rotation of the impellers.

The I-Series rotary meter can be installed for either horizontal or vertical flow by following the step-by-step procedure listed below. The meter is shipped from the factory oriented for vertical downward flow through the meter. If installing for vertical flow, flow entering the top of the meter and flowing down through the meter is recommended. Downward flow aids in washing debris through the meter rather than allowing it to accumulate within the meter. If your installation will have a different flow direction, you will have to make a field adjustment to the index housing and/or the index cover to properly orient the index and the flow direction arrow on the index face.

Installation Steps:

Caution
The meter should not be installed in a low spot in the piping. The low spot may accumulate dirt, debris, condensates or other contaminants that can enter the meter and damage it.

Caution
If it is suspected that the gas is dirty and may carry foreign matter into the meter, place a strainer or filter capable of removing particles 70 microns and larger upstream of the meter. Rotary meters are characterized by tight tolerances between internal moving parts, such as rotor to end plate, rotor to meter body, and rotor to rotor. A properly sized strainer or filter will prevent foreign matter from entering the meter and possibly jamming the rotor mechanism.

- 1) Locate the oil site glass; it is on the end of the meter adjacent to the registration index. Note that the meter is shipped from the factory without oil added. (See section **START-UP**, beginning on page 6, for instructions on how to add oil and to verify that the meter has received the proper amount of oil.)
- 2) Determine whether the direction of gas flow through the meter will be horizontal or vertical.
 - a) If the flow direction is to be vertical, orient the oil site glass so that it is in the “8 o’clock” position as you look at the registration index. (This is the approximate position of the hour hand of a clock at 8 o’clock or 2000 hours.) The influent and effluent connections of the meter will be aligned vertically.
 - b) If the flow direction is to be horizontal, orient the oil sit glass so that it is in approximately the “5 o’clock” position as you look at the registration index. (This is the approximate position of the hour hand of a clock at 5 o’clock or 1700 hours.) The influent and effluent connections of the meter will be aligned horizontally.
- 3) Bolt the meter into the piping. The meter must be installed with the index face perpendicular to the ground. Provide sufficient clearance to work on the meter and to view the registration index and the oil site glass.

Caution
In no case shall the meter be installed with the meter index facing upward (or downward) – i.e. with the index face parallel to the ground. With the index face parallel to the ground, all lubricating oil will drain to the lower end of the meter. The rotor shaft bearing on the higher end of the meter will not be lubricated. The unlubricated bearing will eventually seize, preventing the rotors from turning and stopping the flow of gas.

Caution
To ensure proper oil fill and operation of the meter, it must be installed level to within $\pm 1/16$ "/foot (5mm/m) along both the length and width of the meter.

- 4) The Index housing and index cover can each be rotated so that the index is always properly aligned for easy reading and the flow arrow on the index face shows the proper flow direction. (See **CHANGING METER FLOW DIRECTION**, beginning on page 8.) If you are changing the meter to horizontal flow, rotate the index housing 90° so that the index and text on the index face are upright. (Detailed instructions for doing this are on page 11.) If the horizontal arrow on the index face is pointed in the proper direction, the meter and index are properly oriented. If the arrow on the index face is pointing in the wrong direction, rotate the index cover 180° to align it. (Detailed instructions for doing this are on page 12.)
- 5) Review and comply with the following installation guidelines, and the installation will be complete:
 - a) If there is the possibility of over-ranging the meter, a flow-limiting orifice should be installed a minimum of three to four pipe diameters upstream of the meter. The meter can occasionally be over-ranged up to 120% of its maximum rated flow. If the flow rate exceeds 120% of maximum rated flow or if over ranging occurs frequently or lasts for more than 30 minutes at a time, meter life will be reduced.
 - b) A by-pass line around the meter is recommended for customer applications that cannot tolerate an interruption of gas service.
 - c) The piping connecting flanges must be coaxial and parallel to the meter body connections. The normal tolerances of good piping practice will suffice. If the connecting flanges are not aligned properly, the piping set can put enough stress on the meter body to distort it and cause the rotors to bind. The distance between pipe flanges must take into account both the meter length and the thickness of the sealing gasket. The flange gasket must be positioned so as not to protrude into the gas flow stream. Tighten flange bolts in an alternating pattern to 59 ft-lb (80 N-m) of torque. The bolt size for all of the I-Series meters is 5/8" x 11 UNC.
 - d) If a temperature/pressure correcting instrument is to be installed on the meter, attach the instrument bracket to the meter with two M6x16mm screws. Then attach the instrument to the bracket with standard meter top plate screws. Connect wires from the meter output to the instrument per the corrector's instructions. (See Section **PRESSURE AND TEMPERATURE CORRECTOR**, page 13.)

START-UP

Each I-Series rotary meter is shipped without any oil in the meter. Therefore, it is **imperative that oil be added to the meter before use**. Each meter is shipped with a bottle of lubrication oil. Shell Tellus Oil 10 or any resin-free and acid-free oil with similar properties can be used. Since the I-Series meters oil sumps are connected, you need only fill one oil inlet. Depending upon the orientation of the meter in the pipeline, the oil tap may be on the side or the top of the end plate. Vertical installations will have the tap on the side. Horizontal installations will have the tap on top. Remove the plug and fill the meter with oil until **one half of the oil fill site glass** is covered. Do not overfill oil to above the center hole inside of the site glass. Also, the oil level should not be below the center hole inside of the site glass. The average oil capacity for the vertically oriented meter is 9.1 ounces. For the horizontally installed meter, the oil average oil capacity is 1.5 ounces. Replace and tighten the oil plug. This is a pressure containing seal. **CAUTION: The meter must NOT be under pressure whenever removing the oil plug.** (See **INSPECTION AND MAINTENANCE** for oil diagram.)

Before pressurizing the meter, the inlet, outlet and by-pass (if meter was installed with a by-pass) should have all been in the closed position. Before attempting to pressurize the meter, slowly open the by-pass. After the pressure has stabilized, keeping the **outlet valve closed, slowly open the inlet valve** to the meter. As with most meters, opening the valve too fast can over-speed the meter and cause damage to the meter. Therefore, slowly open the valve so as not to exceed a pressure increase of 5 psig/second (35 kPa/second) downstream of the valve. **Slowly open the outlet valve of the meter.** Close the by-pass valve.

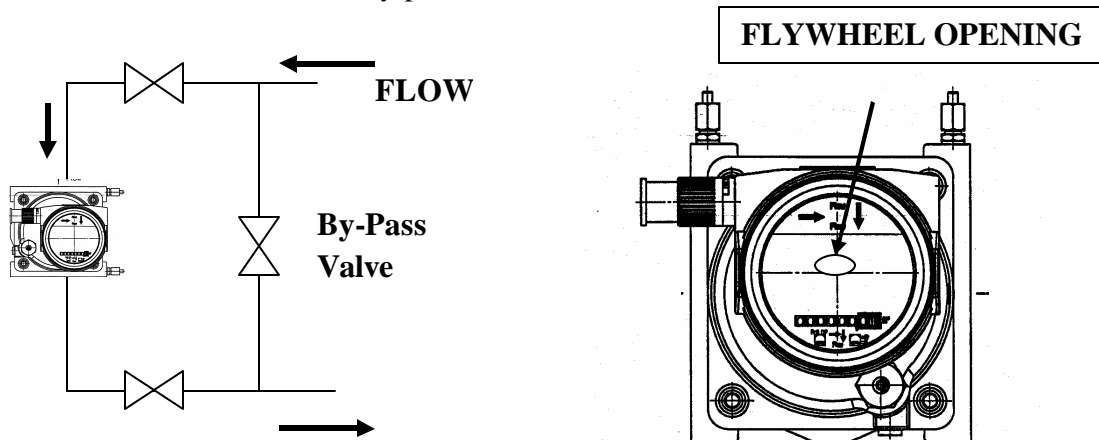

With gas flowing through the meter, watch the flywheel through the index faceplate opening. The wheel should rotate, indicating that the impellers are turning. If the wheel does not rotate, the impellers are not turning. Verify that gas is flowing before proceeding. If the flywheel continues to indicate no impeller movement, open the by-pass valve, close the outlet valve, and close the inlet valve. De-pressurize the meter through one of the pressure tap connections.

WARNING: Do not attempt to remove or begin to remove meter without first de-pressurizing. Check meter installation for misalignment, line blockage, pipe strain, etc. Repeat start up after problem is resolved. Once the index face flywheel meter is rotating, indicating rotation of the impellers, slowly close the by-pass valve. Perform a leak test on connections to finalize installation.

INSPECTION AND MAINTENANCE

If installed and operated in accordance with the instruction provided, the I-Series rotary meters can be expected to operate over a long period of time. The proper lubrication of the meter and the cleanliness of the gas will have the greatest impact on how long the meter will last. Initially, the oil level and meter installation should be checked monthly until an appropriate interval is determined. The frequency of inspections will depend on the cleanliness of the gas, and the rate that the meter is operating.

The oil level should be checked when the meter impellers are not rotating. When rotating, the oil is being circulated to the bearing and the site glass will not provide an accurate indication of the amount of oil actually in the meter reservoir. When the oil level is below the center hole in the site glass, oil should be added. **CAUTION: The meter must NOT be under pressure whenever removing the oil plug.** The oil change frequency will also depend upon the cleanliness of the gas. The darker the oil color, the more dirt that it has accumulated. With a clean gas installation, the oil may not need changed for 6 years. When changing the meter oil, remove the bottom oil drain and dispose of the oil in accordance with local codes.

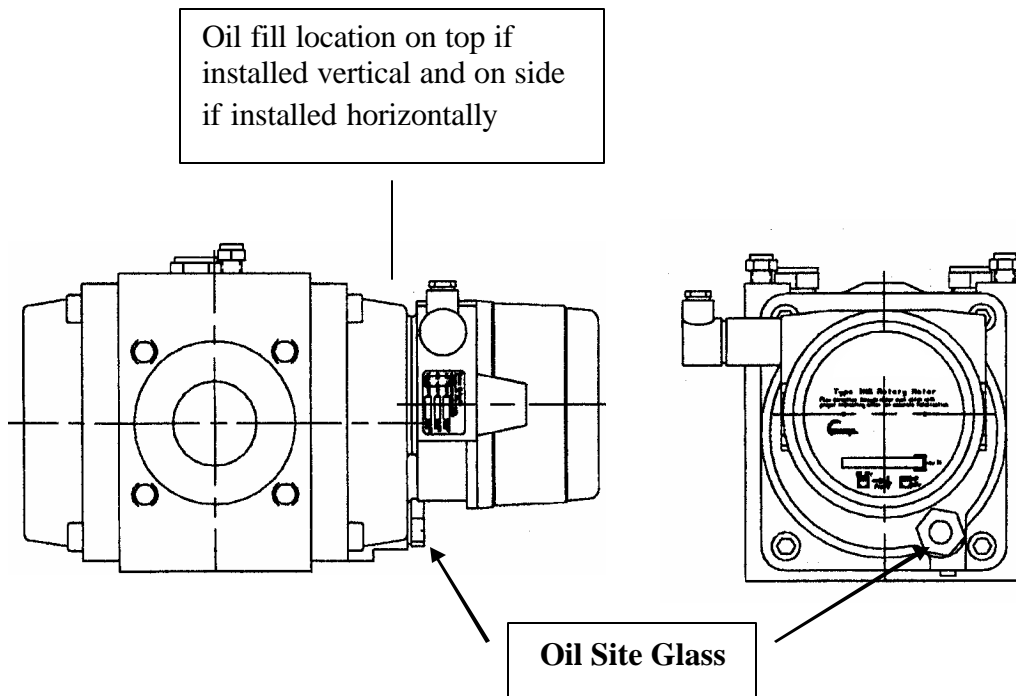

Check the meter installation for level. The settling of the earth, especially for outside installations of recently graded areas, can cause the meter level to deviate by more than the allowable 1/16" per foot.

To determine the operational condition of the meter, a differential test can be conducted across the meter and the results compared with the differential pressures of a new meter. Conditions such as dirt, debris, bearing wear, and over filling of oil can increase the resistance of the impellers to rotate, resulting in a higher pressure differential to flow gas through the meter. The test can be conducted while the meter is in operation, and is performed using a differential pressure manometer. **CAUTION: Only trained personnel using approved equipment should conduct differential pressure testing. Depending upon the installations, the differential manometer may be subjected to inlet pressures as high as 175 psig.**

Differential pressure increases above 50% of the differential pressure of a new meter should be removed for servicing. Removing the meter from service and flushing the rotors with a solvent such as kerosene or mineral spirits will normally remove foreign dirt or debris, and return the meter to acceptable levels. **WARNING: Do not attempt to remove or begin to remove meter without first de-pressurizing. CAUTION: If using compressed air to dry the impellers, be sure not to over-speed the meter.**

CHANGING METER FLOW DIRECTION

The direction of flow for any Invensys Metering Systems I-Series rotary meter can be changed to fit the application. Shipped from the factory, the meters are setup to measure in the recommended vertical down orientation, with the flow entering into the top of the meter and flowing down through the meter. Note the locations of the index cover and index housing when following the procedures to change flow directions.

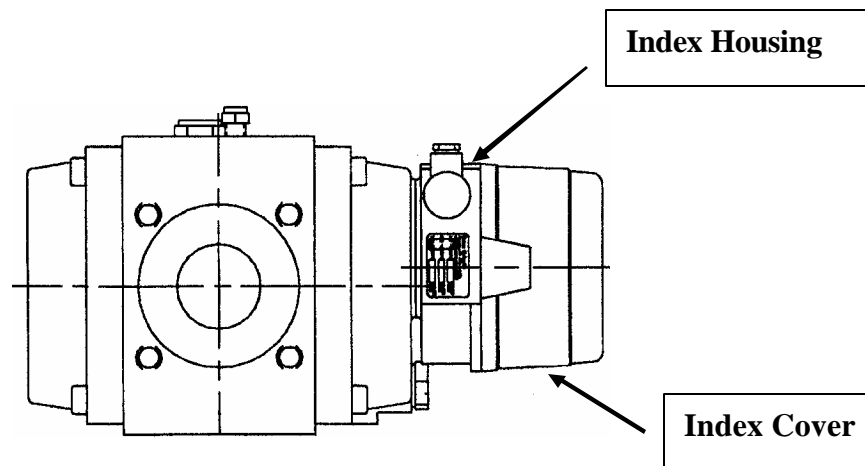



Index face is shown rotated for downward flow

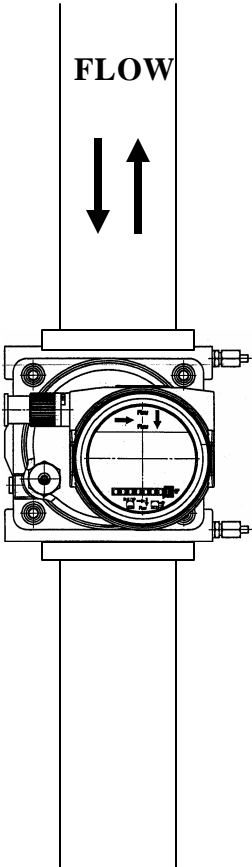

VERTICAL ROTARY METER INSTALLATION



Index face is shown rotated for left to right flow

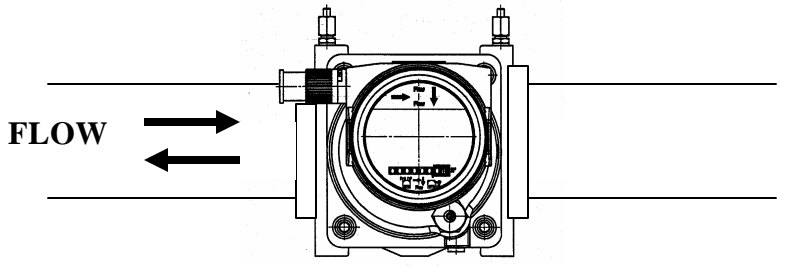

HORIZONTAL ROTARY METER INSTALLATION

To switch from vertical to horizontal flow:

1. Cut the seal wire connecting the index cover seal screws to the index housing seal screw.
2. Back off the index housing seal screw by turning counter clockwise three complete turns.
3. Locate the two set screws around the perimeter of the index housing and back that off also by turning counter clockwise three full turns. The set screws (and seal screw) will back completely out if desired.
4. Facing toward the index cover as though you were reading the meter odometer, rotate the entire meter housing with index cover clockwise 90 degrees.
5. Tighten the seal screw and two set screws. Note if you still want to provide a seal wire you can swap out one of the set screws for the seal screw and run a wire back to the index cover seal screw.

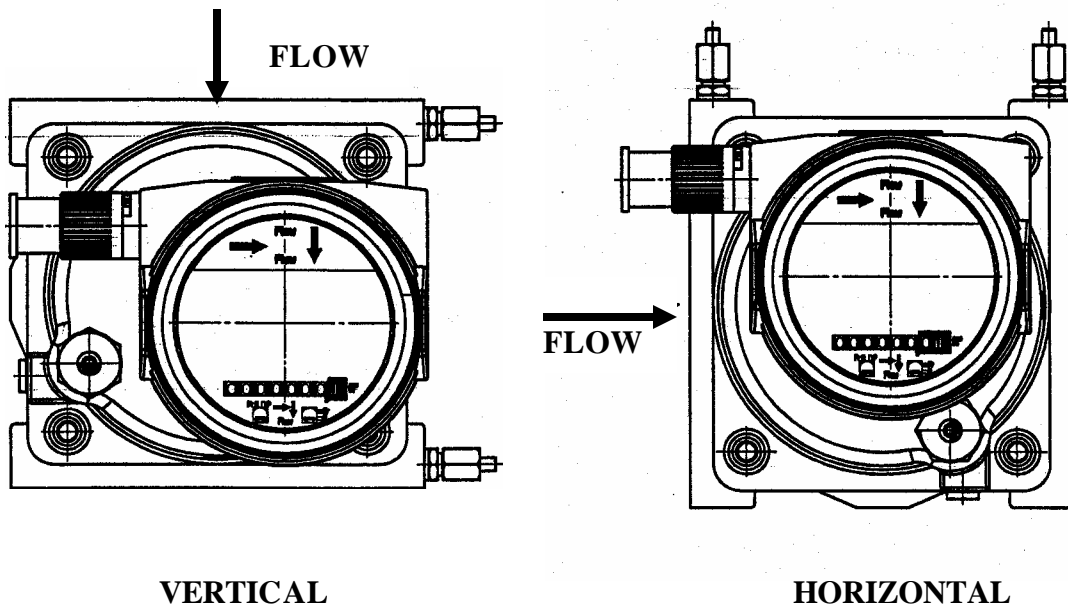

To change the flow direction (change inlet to outlet):

1. Cut the seal wire connecting the index cover seal screw to the index housing seal screw.
2. Back off the index cover seal screw by turning counter clockwise three complete turns.
3. Locate the two set screws around the perimeter of the index cover and back that off also by turning counter clockwise three full turns. The set screws (and seal screw) will back completely out if desired.
4. With the tip of your standard screwdriver, pry the index cover from the index housing. Pry at one of the sides that are flat and come out from the circular edge. Be careful not to nick the paint.
5. With the cover removed, note that there are two odometers on the index face. Rotate the index cover 180 degree to cover the index that had been displayed. The arrows on the index faceplate should now point in the opposite flow direction.
6. Press the cover over the o-ring seal evenly so as not to damage the o-ring.
7. Tighten the seal screw and two set screws. Note if you still want to provide a seal wire you can swap out one of the set screws for the seal screw and run a wire and back to the index housing seal screw.

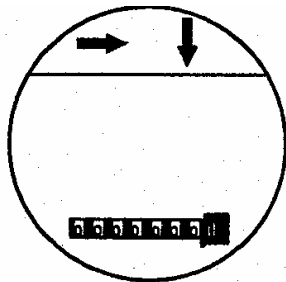

**LEFT TO RIGHT
TOP TO BOTTOM**

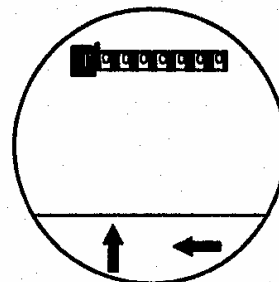

**RIGHT TO LEFT
BOTTOM TO TOP**

PRESSURE AND TEMPERATURE CORRECTOR

The I-Series rotary meters come with two pressure taps and two temperature taps for the installation of a pressure and temperature corrector. An adapter plate is available that attaches to the index housing with two M6 x 16mm screws. Depending on the corrector, it can then attach to the index plate. The corrector will need to have the ability to take a low frequency pulse. The meter itself will need to have at least one single pulse output to drive the corrector. (**See PULSE OUTPUTS**) In addition, if temperature correction is being performed, the meter will need thermowells to replace the temperature screw plugs. The second thermowell is used to measure the reference temperature.

PULSE OUTPUTS

I-Series rotary meters can be ordered with no pulse outputs, one low frequency pulse output, or two low frequency pulse outputs. Reed switches are used to generate the pulses. The switches are internal to the meter and cannot be retrofitted. The 6-pin pulse output connector uses easy screw type wire connections. It also utilizes a hex style end that allows for 8 different positions at which to direct the wires.

The following table provides the conversion from pulses to flow.

Model	Pulses per cubic meter	Pulses per cubic foot
I2.3	10	0.1
I3.5	10	0.1
I5.6	1	0.1
I8.8	1	0.1

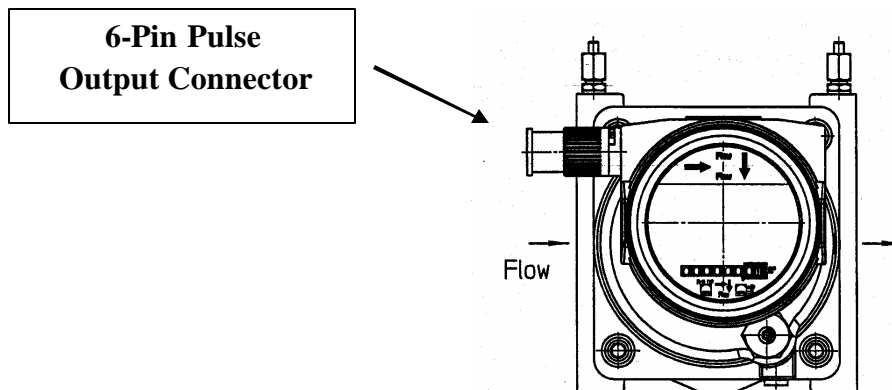

METER DIMENSIONS

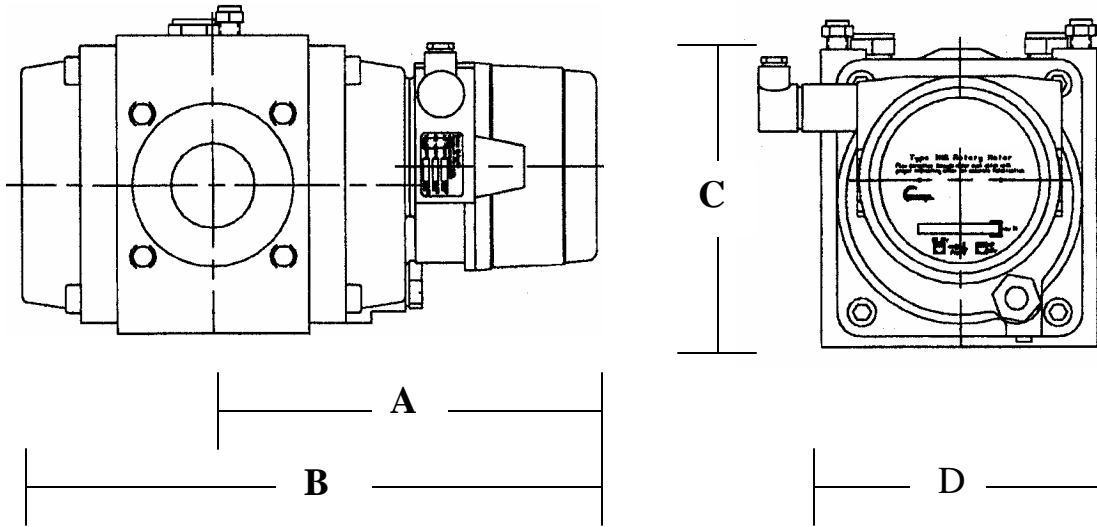

Model	A	B	C	D
I2.3	9.11"	13.78"	7.09"	6.73"
I3.5	9.11"	13.78"	7.09"	6.73"
I5.6	10.49"	16.54"	7.09"	6.73"
I8.8	12.62"	20.79"	8.46"	9.49"

