



PMX-EC[®] Water Meters

Multi-Jet Type Direct Drive Cold Water Meters

5/8" (DN 15mm), 3/4" (DN 20mm) and 1" (DN 25mm) Sizes

Description

Applications: Measurement of cold water where flow is in one direction only; in residential, commercial and industrial services.

Conformance To Standards: Sensus PMX-EC[®] Water Meters meet the requirements of NSF Standard 61 and comply with ANSI/AWWA Standard C700-latest revision. Each meter is tested to insure compliance with AWWA standards.

Construction: Sensus PMX-EC[®] Water Meters consist of two basic components: maincase; measuring chamber with register. Maincases are of bronze C84400 alloy, which has been coated internally and externally with a durable, corrosion resistant fusion bonded epoxy, with externally-threaded spuds. Measuring chambers and Register are made of Polystyrene, Nylon, and Polycarbonate. These materials are corrosion-resistant, tailored thermoplastic material formulated for long-term performance and especially suitable for aggressive water conditions. Maincase Retaining Ring is available in bronze.

Register: The PMX-EC[®] register is a direct drive water lubricated, design which has proven reliable over varying water conditions. The direct drive design eliminates the possibility of magnetic coupling slip. Dirt contamination, tampering and lens fogging problems will not be a problem. Standard register includes a straight-reading, odometer-type totalization display; two hands on the face plate, one showing the tenths and one showing the hundredth value of the face plate with a low flow (leak) indication. Digital remote reading systems are available for all PMX-EC[®] Water Meters. (See other side of sheet for additional information.)

Tamperproof Features: Because of the unique top entry design, customers are not as likely to remove the head ring to obtain free water. A special tool, available only to water utilities, is required to remove the head ring. Every PMX-EC[®] meter has a seal wire attached so the utility can tell if a customer has tampered with the meter.

Direct Drive: The PMX-EC[®] features a hydrodynamically cushioned design that eliminates premature wear of components. The impeller is virtually weightless in water and therefore responds to the smallest change in flow rate.

Operation: Water flows through the meter's strainer and into the measuring chamber where it drives the impeller. The impeller is supported on both the top and bottom. The bearing in the impeller is of manmade sapphire, and is balanced on a nylon shaft. The upper bearing is located within the register and supports the shaft with minimal resistance. The impeller transmits the rotation to the register which is connected to the register gear train. The register reduces the impeller's rotation into volume totalization unites displayed on the dial face.

Maintenance: Sensus PMX-EC[®] Water Meters are engineered to provide long-term value and virtually maintenance-free operation. Simplicity of design and precise machining of components allows interchangeability of parts of like-size meters, reduced parts inventory requirements, and ease of maintenance. The register can be removed without relieving the water pressure or removing the case from the installation.

As an alternative to utility repair, Sensus offers maintenance programs to provide factory reconditioning of the main case and replacement component at low fixed prices. See bulletin MJ-299.

Connections: Tailpieces/Unions for installing the meters on a variety of pipe types and sizes are available.

Guarantee: Sensus PMX-EC[®] Water Meters are backed by "The Sensus Guarantee." Ask your Sensus representative for details or see Bulletin G-500.

Specifications



5/8" PMX-EC[®]
(DN 15mm)

3/4" PMX-EC[®]
(DN 20mm)

1" PMX-EC[®]
(DN 25mm)

SERVICE	Measurement of cold water with flow in one direction only.
NORMAL OPERATING FLOW RANGE^①	5/8" (DN 15mm) size: 1 to 20 gal/min. (0.25 to 4.5 m ³ /h) 3/4" (DN 20mm) size: 2 to 30 gal/min. (0.45 to 7.0 m ³ /h) 1" (DN 25mm) size: 3 to 50 gal/min. (0.7 to 11.0 m ³ /h)
ACCURACY	100% ± 1.5% of actual thru put in normal flow range.
LOW FLOW REGISTRATION	5/8" size: 97% at 1/4 gal/min. (0.06 m ³ /h) 3/4" size: 97% at 1/2 gal/min. (0.10 m ³ /h) 1" size: 97 at 3/4 gal/min (0.15 m ³ /h)
MAXIMUM PRESSURE LOSS	5/8" size: 7.0 psi at 20 gal/min. (0.5 bar at 4.5 m ³ /h) 3/4" size: 9.0 psi at 30 gal/min. (0.6 bar at 7.0 m ³ /h) 1" size: 7.3 psi at 50 gal/min. (0.5 bar at 11.0 m ³ /h)
MAXIMUM OPERATING PRESSURE	150 psi (10.0 bar)
MEASUREMENT ELEMENT	Multi-Jet
REGISTER	Straight reading, hermetically sealed, Direct Drive. Remote reading unit optional.
REGISTRATION	10 gallons, 1 cubic foot or 0.01 m ³ /sweep hand revolution. 10,000,000 gallons, 1,000,000 cubic feet or 10,000 m ³ capacity. 6 odometer wheels.
METER CONNECTIONS^②	5/8" (DN 15mm) size: 3/4" (26.44mm) threads 5/8" x 3/4" (DN 15mm x 33mm) size: 1" (33.25) threads 3/4" (DN 20mm) size: 1" (33.25 threads) 3/4" x 1" (DN 20mm x 42mm) size: 1-1/4" (41.91mm) threads 1" (DN 25mm) size: 1-1/4" (41.91mm) threads (All threads are straight pipe, external type, conforming to ANSI B1.20.1)
MATERIALS	Register Lid — synthetic polymer (standard), Bronze (optional) Hinge Pin — Brass Retaining Ring — Bronze Slip-ring — Polystyrene Lens — Acrylic Top Seal — Rubber Register — Polystyrene, Nylon, Polycarbonate Measuring chamber — Polystyrene, Nylon, Polycarbonate Strainer — Synthetic polymer Maincase — Bronze coated with fusion bonded epoxy Locking Screw — Brass Flat Seal — Fibre Regulating Screw — Acetal

① Maximum rates listed are for intermittent flow only. Maximum continuous flow rates as specified by AWWA are: 5/8" (DN 15mm) — 10 gal/min (2.3 m³/h), 3/4" (DN 20mm) — 15 gal/min (3.4 m³/h) 1" (DN 25mm) — 25 gal/min (5.7 m³/h)

② Unless otherwise noted, 5/8" size and 5/8" x 3/4" characteristics are identical. (5/8" x 3/4" designates 5/8" with 3/4" connection thread.) Also unless otherwise noted 3/4" size and 3/4" x 1" size characteristics are identical. (3/4" x 1" designates 3/4" with 1" connection thread.)

Metric designation is the normal bore x the outside diameter.

Multi-Jet Type Direct Drive Cold Water Meters

5/8" (DN 15mm), 3/4" (DN 20mm) and 1" (DN 25mm) Sizes

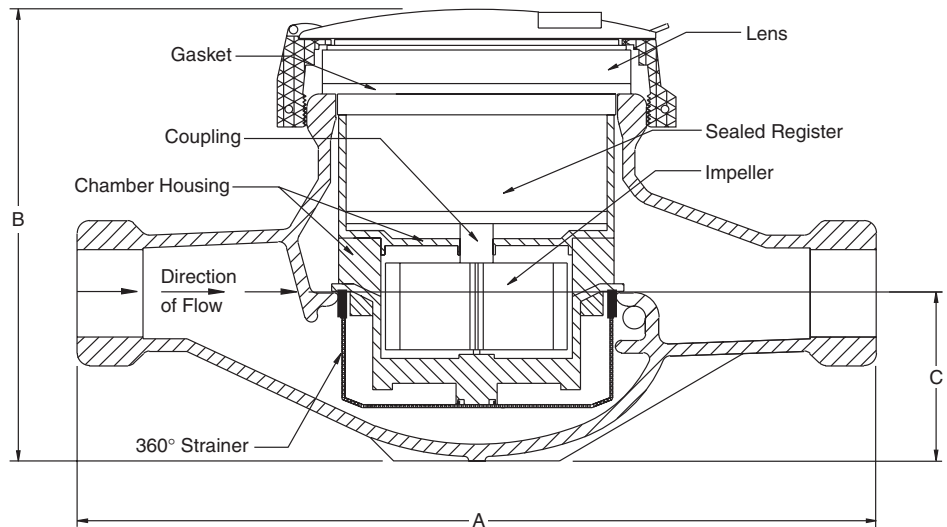
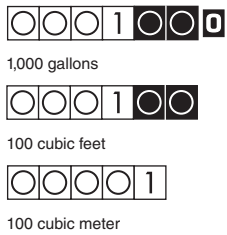

Dimensions and Net Weights

Meter Size	A	B	C	Width	Net Weight
5/8" (DN 15mm)	7-1/2" (190mm)	4-3/4" (121mm)	1-5/8" (41mm)	3-3/4" (96mm)	4 lbs (1.8 kg)
5/8" x 3/4" DN 15mm x 33mm)	7-1/2" (190mm)	4-3/4" (121mm)	1-5/8" (41mm)	3-3/4" (96mm)	4 lbs (1.8 kg)
3/4" Short (DN 20mm)	7-1/2" (190mm)	4-3/4" (121mm)	1-5/8" (41mm)	3-3/4" (96mm)	4 lbs (1.8 kg)
3/4" (DN 20mm)	9" (229mm)	4-3/4" (121mm)	1-5/8" (41mm)	3-3/4" (96mm)	4.5 lbs (2 kg)
3/4" x 1" (DN 20mm x 42mm)	9" (229mm)	4-3/4" (121mm)	1-5/8" (41mm)	3-3/4" (96mm)	4.5 lbs (2 kg)
1" (DN 25mm)	10-3/4" (273mm)	5-1/4" (133mm)	2-1/4" (57mm)	5-1/4" (133mm)	7 lbs (3.2 kg)

Reed Switch

For use with all sizes of Sensus PMX-EC[®] Multi-Jet

REMOTE SYSTEMS—Sensus provides a contact closure switch which may be used with any PMX-EC[®] meter and can be connected to many devices which utilize a digital input. By providing a simple contact closure the utility can then decide if touch, phone, radio or a combination of third party AMR devices will fit their needs. The contact closure will provide a pulse with each revolution of the pointer.

The sensor is totally sealed in a plastic housing and filled with a non-toxic gel to prevent moisture intrusion. The reed switch is attached to the PMX-EC[®] lens by four special screws, providing the utility with an effective means to prevent tampering. With simple installation this product can retro installed PMX-EC[®] meters. Using the same sensor for all sizes, means the utility can carry less inventory, and standardize installation procedures.

Although this device is designed for rugged environmental installations it is a highly sensitive electronic sensor and should be handled with care. Once the switch is installed on the meter you can not carry the meter by the harness or use the harness for any reason other than to connect to the AMR device.

ELECTRICAL CHARACTERISTICS:

- Contact Rating: 10 Watts
- Max. Voltage: 20 Volts
- Max. Switching: 0.5 Amps
- Resistance(closed): <101Ω hms
- Min. On State: >1 Sec
- Max. Frequency: <5 Hz
- Cable: 22 Awg, 2 con. with shield & drain
- Length: 15 ft standard

ENVIRONMENTAL CHARACTERISTICS:

- Working Temp: -45°F to 125°F
- Humidity: 100%

AUTHORIZED SENSUS DISTRIBUTOR



P.O. Box 487 • 450 N. Gallatin Avenue
Uniontown, PA 15401
1-800-METER-IT • 1-800-638-3748

Fax: Direct to Factory
Local: 724-439-7729 • Toll Free: 1-800-888-2403
www.sensus.com (select "North America Water")
Email: h2oinfo@sensus.com