



PMX-EC® Water Meters

Multi-Jet Type Direct Drive Cold Water Meters

1-1/2" (DN 40mm) and 2" (DN 50mm) Sizes

Description

Applications: Measurement of cold water where flow is in one direction only; in residential, commercial and industrial services.

Conformance To Standards: Sensus PMX-EC® Water Meters meet the requirements of NSF Standard 61 and comply with ANSI/AWWA Standard C700-latest revision. Each meter is tested to insure compliance with AWWA standards.

Construction: Sensus PMX-EC® Water Meters consist of two basic components: main case; measuring chamber with register. Maincases are of bronze C84400 alloy, which has been coated internally and externally with a durable, corrosion resistant fusion bonded epoxy, with either flanges, internally or externally-threaded spuds. Measuring chambers and registers are made of Polystyrene, Nylon, and Polycarbonate. These materials are corrosion-resistant, tailored thermoplastic materials formulated for long-term performance and especially suitable for aggressive water conditions. Maincase Retaining Ring is available in bronze.

Register: The PMX-EC® register is a direct drive water lubricated design which has proven reliable over varying water conditions. The direct drive design eliminates the possibility of magnetic coupling slip. Dirt contamination, tampering and lens fogging will not be a problem. Standard register includes a straight-reading, odometer-type totalization display; two hands on the face plate, one showing the tenths and one showing the hundredth value of the face plate with a low flow (leak) indication. Digital remote reading systems are available for all PMX Water Meters. (See other side of sheet for additional information.)

Tamperproof Features: Because of the unique top entry design, customers are not as likely to remove the head ring to obtain free water. A special tool, available only to water utilities, is required to remove the head ring. Every PMX-EC® meter has a seal wire attached so the utility can tell if a customer has tampered with the meter.

Direct Drive: The PMX-EC® features a hydrodynamically cushioned design that eliminates premature wear of components. The impeller is virtually weightless in water and therefore responds to the smallest change in flow rate.

Operation: Water flows through the meter's strainer and into the measuring chamber where it drives the impeller. The impeller is supported on both the top and bottom. The bearing in the impeller is of man made sapphire, and is balanced on a stainless steel shaft. The upper bearing is located within the register and supports the shaft with minimal resistance. The impeller transmits the rotation to the register which is connected to the register gear train. The register reduces the impeller's rotation into volume totalization units displayed on the dial face.

Maintenance: Sensus PMX-EC® Water Meters are engineered to provide long-term value and virtually maintenance-free operation. Simplicity of design and precise machining of components allows interchangeability of parts of like-size meters, reduced parts inventory requirements, and ease of maintenance.

As an alternative to utility repair, Sensus offers maintenance programs to provide factory reconditioning of the main case and replacement component at low fixed prices. See bulletin MJ-299.

Connections: Tailpieces/Unions for installing the meters on a variety of pipe types and sizes are available.

Guarantee: Sensus PMX-EC® Water Meters are backed by "The Sensus Guarantee." Ask your Sensus representative for details or see Bulletin G-500.

Specifications



1-1/2" PMX-EC®
(DN 40mm)

2" PMX-EC®
(DN 50mm)

SERVICE	Measurement of cold water with flow in one direction only.
NORMAL OPERATING FLOW RANGE ①	1-1/2" (DN 40mm) size: 5 to 100 gal/min. (1.1 to 23.0 m ³ /h) 2" (DN 50mm) size: 8 to 160 gal/min. (1.8 to 36.0 m ³ /h)
ACCURACY	100% ± 1.5% of actual thru put in normal flow range.
LOW FLOW REGISTRATION	1-1/2" (DN 40mm) size: 97% at 1/2 gal/min. (0.35 m ³ /h) 2" (DN 50mm) size: 97% at 3/4 gal/min. (0.45 m ³ /h)
MAXIMUM PRESSURE LOSS	1-1/2" (DN 40mm) size: 3.3 psi @ 50 gal/min. (0.24 bar at 11.4 m ³ /h) 2" (DN 50mm) size: 3.3 psi @ 80 gal/min. (0.24 bar at 18.2 m ³ /h)
MAXIMUM OPERATING PRESSURE	225 psi (16.0 bar)
MEASUREMENT ELEMENT	Multi-Jet
REGISTER	Straight reading, Direct drive. Remote reading unit optional.
REGISTRATION	100,000,000 gallons, 100 gallon/sweep hand revolution. 10,000,000 Cubic Feet, 10 C.F. /sweep hand revolution. 100,000 Cubic Meter 0.1 m ³ /h /sweep hand revolution.
METER CONNECTIONS ②	Flanged 1-1/2": two bolt oval flanged. Female 1-1/2": NPT internal pipe threads. Male 1-1/2": NPSM external pipe threads. Flanged 2": two bolt oval flanged. Female 2": NPT internal pipe threads. Male 2": NPSM external pipe threads.
MATERIALS	Register Lid — synthetic polymer (standard), Bronze (optional) Hinge Pin — Brass Retaining Ring — Bronze Slip-ring — Polystyrene Lens — Acrylic Top Seal — Rubber Register — Polystyrene, Nylon, Polycarbonate Measuring chamber — Polystyrene, Nylon, Polycarbonate Strainer — Synthetic polymer Maincase — Bronze coated with fusion bonded epoxy Locking Screw — Brass Flat Seal — Fibre Regulating Screw — Acetal

① Maximum rates listed are for intermittent flow only. Maximum continuous flow rates as specified by AWWA are: 1-1/2" (DN 40mm) — 50 gal/min (11.0 m³/h), 2" (DN 50mm) — 80 gal/min (18.0 m³/h)

② Flanged spuds are standard for 1-1/2" DN 40mm) and 2" (DN 50mm) size meters and will be furnished unless otherwise specified.

Multi-Jet Type Direct Drive Cold Water Meters

1-1/2" (DN 40mm) and 2" (DN 50mm) Sizes



1,000 gallons



100 cubic feet



100 cubic meter

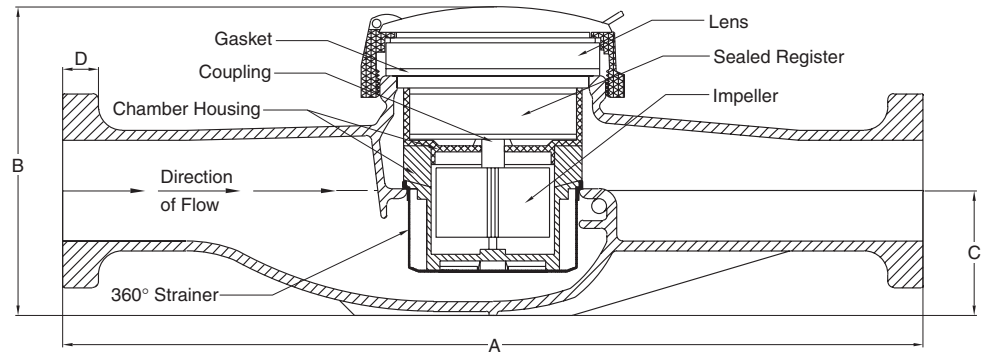

Dimensions and Net Weights

Meter Size	Connections	A Length	B Height	C Center	D Flange	Width	Bolt Circle	Number of Bolts	Bolt Size	Net Weight
1-1/2" (DN 40mm)	Flanged	13" (330mm)	6-1/2" (165mm)	3-1/4" (83mm)	19/32" (15mm)	5-1/2" (140mm)	4.016" (18mm)	2	5/8" (16mm)	17 lbs. (7.7 kg)
	Male Thread	12-5/8" (321mm)	6-1/2" (165mm)	3-1/4" (83mm)	N/A	5-1/4" (133mm)	N/A	N/A	N/A	13-1/2 lbs. (6.2 kg)
	Female Thread	12-5/8" (321mm)	6-1/2" (165mm)	3-1/4" (83mm)	N/A	5-1/4" (133mm)	N/A	N/A	N/A	13-1/2 lbs. (6.2 kg)
2" (DN 50mm)	Flanged	17" (432mm)	6-3/4" (172mm)	3-5/8" (92mm)	23/32" (18mm)	6-1/8" (156mm)	4.488" (114mm)	2	3/4" (19mm)	22-1/2 lbs (10.2 kg)
	Male Thread	15-1/4" (388mm)	6-3/4" (172mm)	3-5/8" (92mm)	N/A	5-3/4" (146mm)	N/A	N/A	N/A	15-1/4 lbs (9.7 kg)
	Female Thread	15-1/4" (388mm)	6-3/4" (172mm)	3-5/8" (92mm)	N/A	5-3/4" (146mm)	N/A	N/A	N/A	15-1/4 lbs (9.7 kg)
2" Short (DN 50mm)	Oval Flange	10" (254mm)	6-3/4" (172mm)	3-5/8" (92mm)	23/32" (18mm)	6-1/8" (156mm)	4.488" (114mm)	2	3/4" (19mm)	19 lbs (8.6 kg)
	Round Flange	10" (254mm)	6-3/4" (172mm)	3-5/8" (92mm)	23/32" (18mm)	6-1/8" (156mm)	4.488" (114mm)	4	3/4" (19mm)	20 lbs (9 kg)

Reed Switch

For use with all sizes of Sensus PMX-EC[®] Multi-Jet

REMOTE SYSTEMS—Sensus provides a contact closure switch which may be used with any PMX-EC[®] meter and can be connected to many devices which utilize a digital input. By providing a simple contact closure the utility can then decide if touch, phone, radio or a combination of third party AMR devices will fit their needs. The contact closure will provide a pulse with each revolution of the pointer.

The sensor is totally sealed in a plastic housing and filled with a non-toxic gel to prevent moisture intrusion. The reed switch is attached to the PMX-EC[®] lens by four special screws, providing the utility with an effective means to prevent tampering. With simple installation this product can retro installed PMX-EC[®] meters. Using the same sensor for all sizes, means the utility can carry less inventory, and standardize installation procedures.

Although this device is designed for rugged environmental installations it is a highly sensitive electronic sensor and should be handled with care. Once the switch is installed on the meter you can not carry the meter by the harness or use the harness for any reason other than to connect to the AMR device.

ELECTRICAL CHARACTERISTICS:

Contact Rating:	10 Watts
Max. Voltage:	20 Volts
Max. Switching:	0.5 Amps
Resistance(closed):	<101Ω hms
Min. On State:	>1 Sec
Max. Frequency:	<5 Hz
Cable:	22 Awg, 2 con. with shield & drain
Length:	15 ft standard

ENVIRONMENTAL CHARACTERISTICS:

Working Temp:	-45°F to 125°F
Humidity:	100%

AUTHORIZED SENSUS DISTRIBUTOR



P.O. Box 487 • 450 N. Gallatin Avenue
Uniontown, PA 15401
1-800-METER-IT • 1-800-638-3748

Fax: Direct to Factory
Local: 724-439-7729 • Toll Free: 1-800-888-2403
www.sensus.com (select "North America Water")
Email: h2oinfo@sensus.com