



Series "W" Turbo Meters

Model W-2000 DRSL

(Direct Reading Slim-Line) Bronze Magnetic Drive Size 6" (DN 150mm)



Intelligent Communications Encoder (ICE) Register

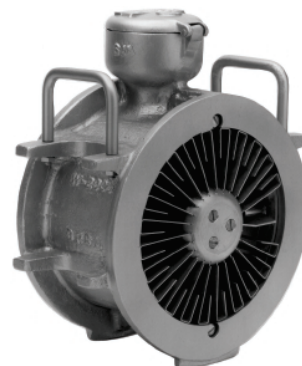

W-2000 DRSL Turbo Meter

Description

Model: W-2000 DRSL Turbo Meter is based on the turbine principle of measurement; its operating range is from 30 to 2000 gallons per minute (6.8 to 450 m³/h) with registration accuracy of 100% ± 1.5% of actual thruput.

Performance: The meter's unique design permits continuous operation up to its rated maximum flow capacity, without affecting long term accuracy or causing undue wear.

Construction: The meter incorporates the measuring chamber and meter body in a specially designed maincase. Included in the maincase are the flow straightening vane assembly, measuring element (rotor), adjusting vane (for calibration) and hermetically sealed Direct Reading (DR) register.

Magnetic Drive: The Right Angle Magnetic Drive eliminates conventional worm or miter gears normally required for horizontally mounted rotors or turbine measuring elements. Registration is accomplished by combining the magnetic actions of a driver magnet (embedded in the rear face of the rotor), a three-legged flux carrier and a cylindrical follower magnet attached to the gear train shaft inside the register's magnet well. Water flowing through the meter causes the rotor (with magnet) to turn; as one of the magnet poles passes one of the flux carrier legs, the magnetic force is transmitted through the flux carrier leg to the follower magnet, causing the register shaft to rotate. The only moving part in water is the rotor assembly.

Rotor: The thermoplastic rotor with graphite bearing rotates on a chrome plated stainless steel shaft. The rotor assembly is virtually weightless in water, thus adding to bearing life.

Maintenance: The measuring chamber and straightening vanes can be removed, repaired and/or replaced, but the maincase must be removed from the line. A spool piece is also available to keep the line in service while the meter is repaired and recalibrated. Factory testing, repair and measuring chamber exchange programs are available.

Instrumentation: For applications requiring instrumentation, the high Speed Pick-up (HSP) register and Impulse Contact (IC) register are available. See data sheets E-1116 (HSP register) and E-1112 (IC register) for details.

Specifications

SERVICE	Measurement of cold water up to 80°F (27°C) with flow in one direction only.
OPERATING RANGE	Continuous Flows: 30 to 2000 gpm (6.8 to 450 m ³ /h) Intermittent Flows: 2500 gpm max. (570 m ³ /h)
ACCURACY	100% ± 1.5% of actual thruput
LOW FLOW	95% at 20 gpm (4.5 m ³ /h)
PRESSURE LOSS	3.8 psi at 2000 gpm (.2 bar at 450 m ³ /h)
MAXIMUM OPERATING PRESSURE	150 psi (10.0 bar)
FLANGE	6" U.S. ANSI B 16.1 Class 125.
REGISTER	Hermetically Sealed Direct Reading Register with Low Flow Indicator. Remote reading unit optional.
METER REGISTRATION	1,000,000,000 gallons 100 gallons/sweep hand revolution 100,000,000 cubic feet 100 cubic feet/sweep hand revolution 1,000,000 m ³ 1 m ³ /sweep hand revolution.
MATERIALS	Maincase—Bronze Straightening Vanes—Stainless Steel Rotor—Thermoplastic Radial Bearing—Graphite Trim—Stainless Steel Thrust Bearings—Tungsten Carbide Magnets—Ceramic

Model W-2000 DRSL

(Direct Reading Slim-Line) Bronze Magnetic Drive Size 6" (DN 150mm)

Head Loss Curve

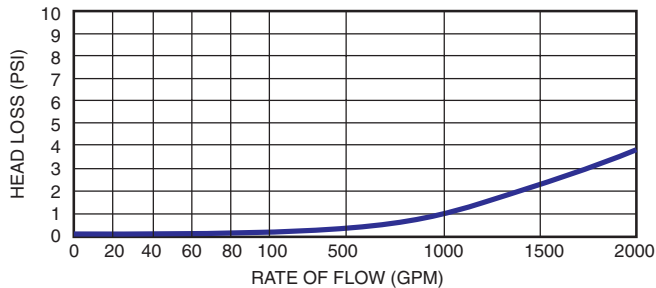

Accuracy Curve

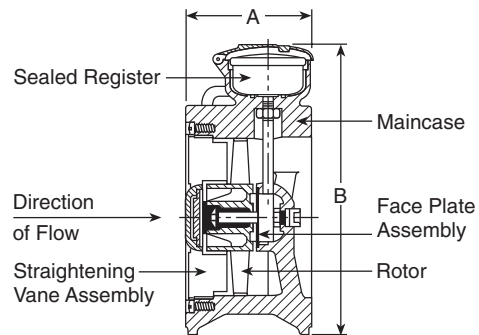
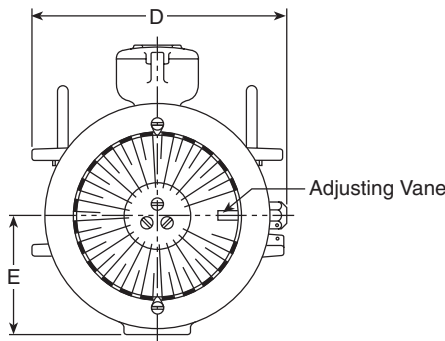
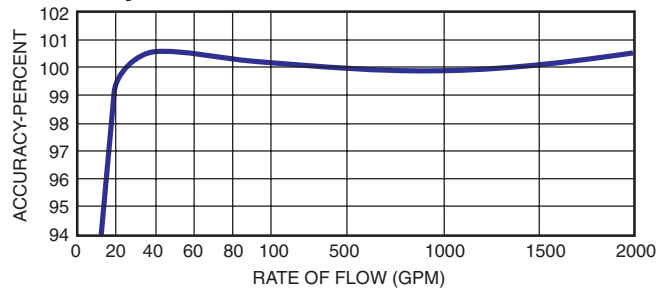

Meter and Pipe Size	Normal Operating Range GPM Minimum Maximum		Dimensions								Net Weight	Shipping Weight	
			Connections	A	B	C	D	E	F	G			H
6" DN 150mm	30 6.8m ³ /h	2000 ^① 450m ³ /h	Flanged	4-3/4"	11"	NA	10"	4-3/8"	NA	NA	NA	28 lbs.	34 lbs.
				121mm	280mm	NA	254mm	115mm	NA	NA	NA	13 kg	15.4 kg

^① For continuous flows; 2500 GPM (570m³/h) maximum for intermittent flows.

Remote Reading Systems

For use with all sizes of Sensus Water Meters

All Sensus AMR systems work with the same absolute encoder Electronic Communications Registers (ECR), enabling the utility to mix and match or easily move from one system to another without changing registers for each.

The TouchRead® Automated Meter Reading and Billing System—is a multipurpose encoder remote system suitable for indoor and/or outdoor use. The ECR Register uses a wired connection between the meter and an outside remote for inside set meters—or a pitlid mounted module, enabling underground meters to be read automatically without opening the meter box or vault. All wired connections and terminals of the TouchRead PitLid (TR/PL) modules and registers are fully sealed at the factory using a special process to ensure protection from water infiltration. The connection terminals of ECR/WP registers are also factory sealed.

Meters equipped for TouchRead System reading can be read with a visual reading device, stand alone AutoGun, and/or reading gun with an AutoRead HandHeld Device. For more information on TouchRead System equipment refer to bulletins AMR-TR, AMR-401, AMR-403, AMR-312 and EXSUMHH.

PhonRead® AMR—is a reliable telephone based call-in system that does not require batteries for operation. It also does not require equipment to be installed at telephone company facilities. PhonRead Meter Interface

Units (MIU) automatically call "in" to the utility office for transferring meter reading data from the meter site to a PC. PhonRead is a transparent AMR system that does not interfere with customers' telephone service. For more information refer to bulletins AMR-PR and AMR-302.

RadioRead® AMR—uses superior Direct Sequence Spread Spectrum modulation to provide reliable, safe and virtually interference free radio-based transmission of reading data from underground or inside-set meters that are equipped with Meter Transceiver Units (MXU). A choice of meter reading options is available. A radio frequency hand-held device (RF-HHD) can be used by a meter reader on foot. The RF-HHD can also be used to collect readings from TouchRead equipped meters, or for manual meter reading entries. A more powerful Vehicle Transceiver Unit (VXU) can be used in any car or truck to read meters while on the move. (A dedicated meter reading vehicle is not required.) For more information refer to bulletins AMR-RR, AMR-301 and AMR-303, and AMR-401.

MultiRead® Port Expanders—can provide the capability to connect multiple ECR equipped meters to a single PhonRead MIU or RadioRead MXU to save the utility time and money for installations such as apartment complexes and shopping centers. Refer to bulletin AMR-305, AMR-306 and AMR-308.

AUTHORIZED SENSUS DISTRIBUTOR



P.O. Box 487 • 450 N. Gallatin Avenue
Uniontown, PA 15401
1-800-METER-IT • 1-800-638-3748

Fax: Direct to Factory
Local: 724-439-7729 • Toll Free: 1-800-888-2403

www.sensus.com (select "North America Water")

Email: h2oinfo@sensus.com